



Chiusura pneumatica CPL80

Pneumatic clamp CPL80

Caratteristiche principali:

- Fianchetti in alluminio
- Dispositivo a ginocchiera
- Angolo di apertura facilmente modificabile
- Perno di controllo della posizione finale
- Leve versatili in ghisa V e H
- 4 possibilità di staffaggio (fronte, retro e sui lati)
- Alesaggio del cilindro pneumatico: 80 mm
- 2 fori di connessione G1/4"
- Finecorsa induttivo (connessione M12x1)
- Comando manuale

Main characteristics:

- Aluminum flanks
- Toggle action mechanism
- Opening angle easily adjustable
- Checking pin for verifying the end position
- Versatile iron steel arms V and H
- 4 mounting areas (front, back, on the sides)
- Pneumatic cylinder bore: 80 mm
- 2 feeding ports G1/4"
- Inductive proximity switch (connection M12x1)
- Hand lever

[PDF](#)

[3D Step](#)

[WEB](#)





Indice.

Index.

Pagina Page	Descrizione Description	
1	Caratteristiche principali / Main characteristics	
2	Codice d'ordine / Ordering example	
3 - 4	Pagina dimensionale Dimensional page	CPL80-V1... / CPL80-H1...
5 - 6		CPL80-V1...S / CPL80-H1...S
7 - 8		CPL80-V1CDS / CPL80-H1CDS
9 - 10		CPL80-V1CDSS / CPL80-H1CDSS
11 - 12		CPL80-V3... / CPL80-H3...
13 - 14		CPL80-V3...S / CPL80-H3...S
15 - 16		CPLM80 V1... / CPLM80 H1...
17 - 18		CPLM80 V1...S / CPLM80 H1...S
19 - 20		CPLM80 V3... / CPLM80 H3...
21 - 22		CPLM80 V3...S / CPLM80 H3...S
23	Diagrammi / Diagrams	
24	Schemi Diagrams	Finecorsa induttivo M12 M12 Inductive proximity switch
		Schema pneumatico / Pneumatic plan
25 - 26	Istruzioni operative Operating instructions	Modifica cambio angolo d'apertura Opening angle change
26 - 27	Ricambi / Spare parts	
27	Note / Notes	

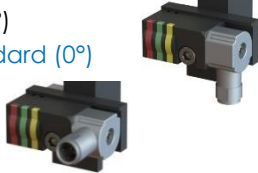

Codice d'ordine.
Ordering example.

CPL80	LA	V1C	I1	G	-	107																																																																
<p>Modello ed alesaggio cilindro: Model and cylinder bore CPL80 chiusura standard CPL alesaggio Ø80mm standard clamp CPL cylinder bore Ø80mm</p> <p>CPLM80 chiusura standard CPL con comando manuale alesaggio Ø80mm standard clamp CPL with hand lever cylinder bore Ø80mm</p> 	<p>Posizione comando manuale: <i>(specificare solo per tipologia CPLM...)</i> Hand lever position: <i>(specify only for CPLM... type)</i> LX: predisposizione leva lever arrangement LA: leva sinistra left lever LB: leva destra right lever</p> 	<p>Finecorsa: Proximity switch: X: senza finecorsa without proximity switch</p> <p>I1: finecorsa induttivo VEP standard (0°) inductive proximity switch VEP standard (0°)</p> <p>I2: finecorsa induttivo VEP (90°) inductive proximity switch VEP (90°)</p> 	<p>Tipologia leva: Type of arm: XXX: senza leva without arm</p> <p>V1C, V1D e V1S (vedere pag. 3) <i>(see page 3)</i> H1C, H1D e H1S (vedere pag. 4) <i>(see page 4)</i> V1CS, V1DS e V1SS (vedere pag. 5) <i>(see page 5)</i> H1CS, H1DS e H1SS (vedere pag. 6) <i>(see page 6)</i> V1CDS (vedere pag. 7) <i>(see page 7)</i> H1CDS (vedere pag. 8) <i>(see page 8)</i> V1CDSS (vedere pag. 9) <i>(see page 9)</i> H1CDSS (vedere pag. 10) <i>(see page 10)</i> V3C, V3D e V3S (vedere pag. 11) <i>(see page 11)</i> H3C, H3D e H3S (vedere pag. 12) <i>(see page 12)</i> V3CS, V3DS e V3SS (vedere pag. 13) <i>(see page 13)</i> H3CS, H3DS e H3SS (vedere pag. 14) <i>(see page 14)</i></p> <p><u>N.B.: è possibile trasformare la chiusura tipo V... nel tipo H... semplicemente cambiando la posizione della leva.</u> <u>NOTE: It's possible to transform the clamp type V... into the type H... simply changing the arm position.</u></p> 	<p>Tipologia fori d'alimentazione: Feeding ports type: G: fori tipo G 1/4" ports type G 1/4" N: fori tipo 1/4" NPT ports type 1/4" NPT</p> 	<p>Angolo d'apertura regolabile: Adjustable opening angle:</p> <table border="1" style="width:100%; border-collapse: collapse;"> <thead> <tr style="background-color: #0070C0; color: white;"> <th rowspan="2">Tipo Type</th> <th colspan="3">CPL80</th> <th colspan="3">CPLM80</th> </tr> <tr style="background-color: #0070C0; color: white;"> <th>da from</th> <th>a to</th> <th>Standard</th> <th>da from</th> <th>a to</th> <th>Standard</th> </tr> </thead> <tbody> <tr> <td>V1...</td> <td rowspan="2">3°</td> <td rowspan="2">135°</td> <td rowspan="2">122°</td> <td>3°</td> <td rowspan="2">122°</td> <td rowspan="2">122°</td> </tr> <tr> <td>V3...</td> <td>3°</td> </tr> <tr> <td>H1...</td> <td>3°</td> <td>103°</td> <td>103°</td> <td>3°</td> <td>103°</td> <td>103°</td> </tr> <tr> <td>H3...</td> <td>3°</td> <td>117°</td> <td>117°</td> <td>3°</td> <td>117°</td> <td>117°</td> </tr> <tr> <td>V1...S</td> <td>3°</td> <td>13°</td> <td>13°</td> <td>3°</td> <td>13°</td> <td>13°</td> </tr> <tr> <td>V3...S</td> <td>3°</td> <td>29°</td> <td>29°</td> <td>3°</td> <td>29°</td> <td>29°</td> </tr> <tr> <td>H1...S</td> <td>3°</td> <td>72°</td> <td>72°</td> <td>3°</td> <td>72°</td> <td>72°</td> </tr> <tr> <td>H3...S</td> <td>3°</td> <td>58°</td> <td>58°</td> <td>3°</td> <td>58°</td> <td>58°</td> </tr> </tbody> </table> <p>Nel caso in cui non indicato, la chiusura verrà fornita con l'angolo d'apertura standard. If not indicated, the clamp will be provided with the standard opening angle.</p>		Tipo Type	CPL80			CPLM80			da from	a to	Standard	da from	a to	Standard	V1...	3°	135°	122°	3°	122°	122°	V3...	3°	H1...	3°	103°	103°	3°	103°	103°	H3...	3°	117°	117°	3°	117°	117°	V1...S	3°	13°	13°	3°	13°	13°	V3...S	3°	29°	29°	3°	29°	29°	H1...S	3°	72°	72°	3°	72°	72°	H3...S	3°	58°	58°	3°	58°	58°
Tipo Type	CPL80			CPLM80																																																																		
	da from	a to	Standard	da from	a to	Standard																																																																
V1...	3°	135°	122°	3°	122°	122°																																																																
V3...				3°																																																																		
H1...	3°	103°	103°	3°	103°	103°																																																																
H3...	3°	117°	117°	3°	117°	117°																																																																
V1...S	3°	13°	13°	3°	13°	13°																																																																
V3...S	3°	29°	29°	3°	29°	29°																																																																
H1...S	3°	72°	72°	3°	72°	72°																																																																
H3...S	3°	58°	58°	3°	58°	58°																																																																



CPL80 H1...

Chiusura, D.80, Ang. Vario, Leva orizzontale, Offset 20
Clamp, D.80, Vario Op. Angle, Horizontal arm, Offset 20

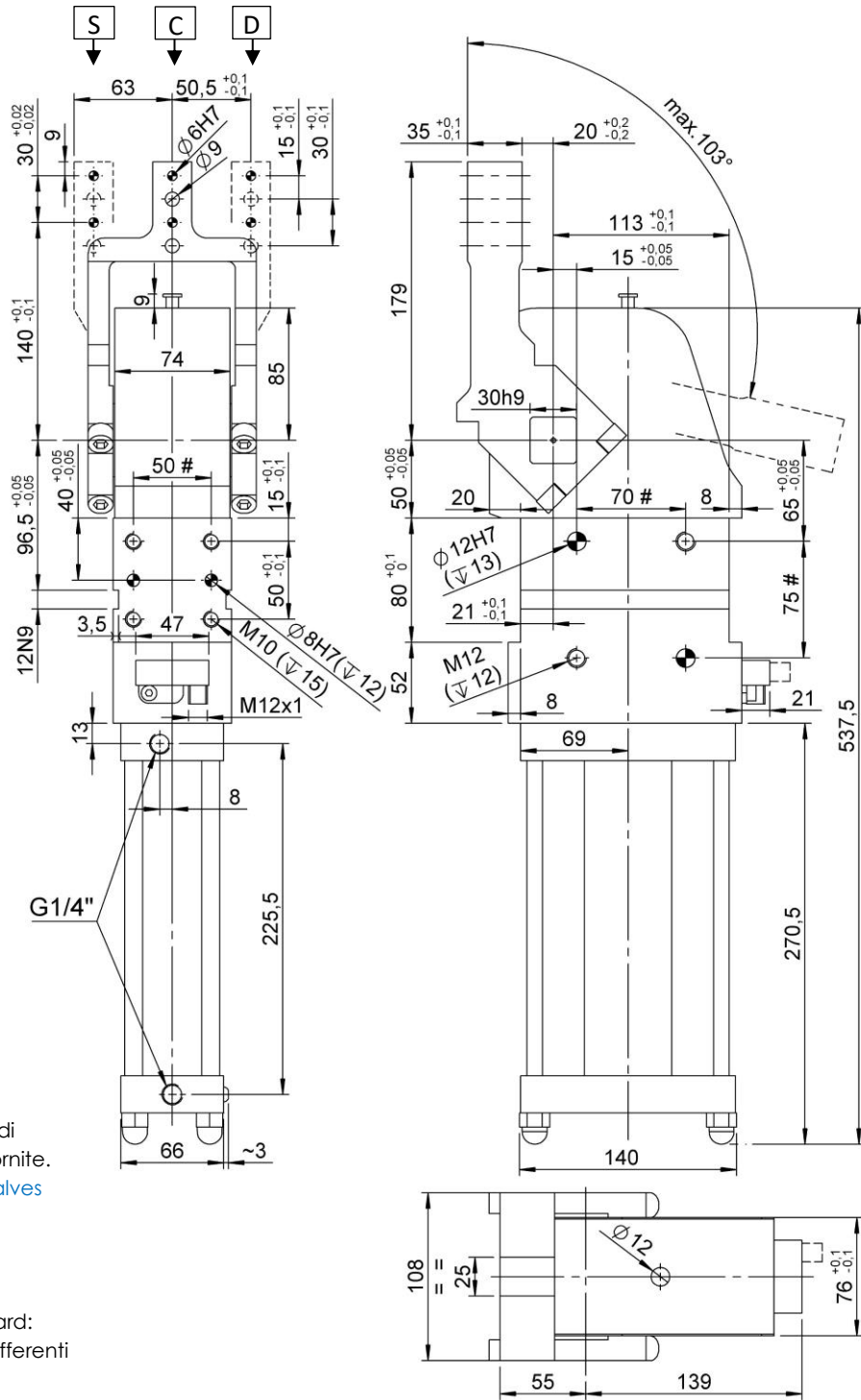

Il dispositivo dev'essere equipaggiato di valvole di regolazione flusso, non fornite.

External throttle check valves must be provided on the assembly. They are not included in the delivery.

Angoli di apertura standard: settabile in 25 posizioni differenti in un range tra 3° e 103°.

Standard opening angles: settabile in 25 different positions in a range between 3° and 103°.

Tolleranze: fori spina ± 0.02 , fori filettati ± 0.1
Tolerances: dowel holes ± 0.02 , screw holes ± 0.1

Modello Type	Alesaggio cilindro Cylinder bore	Momento di ritegno Holding moment	Peso Weight	Pressione d'esercizio Working pressure	Coppia max. di bloccaggio Clamping max. torque (5 bar)	Consumo d'aria max. Max. air consumption (5 bar)
	[mm]	[Nm]	[Kg]	[bar]	[Nm]	[l]
CPL80 H1...	80	2500	~ 14	4 - 8	1000	7,1



CPL80 V1...S

Chiusura, D.80, Ang. Vario, Leva verticale simmetrica, Offset 20
 Clamp, D.80, Vario Op. Angle, Vertical symmetric arm, Offset 20

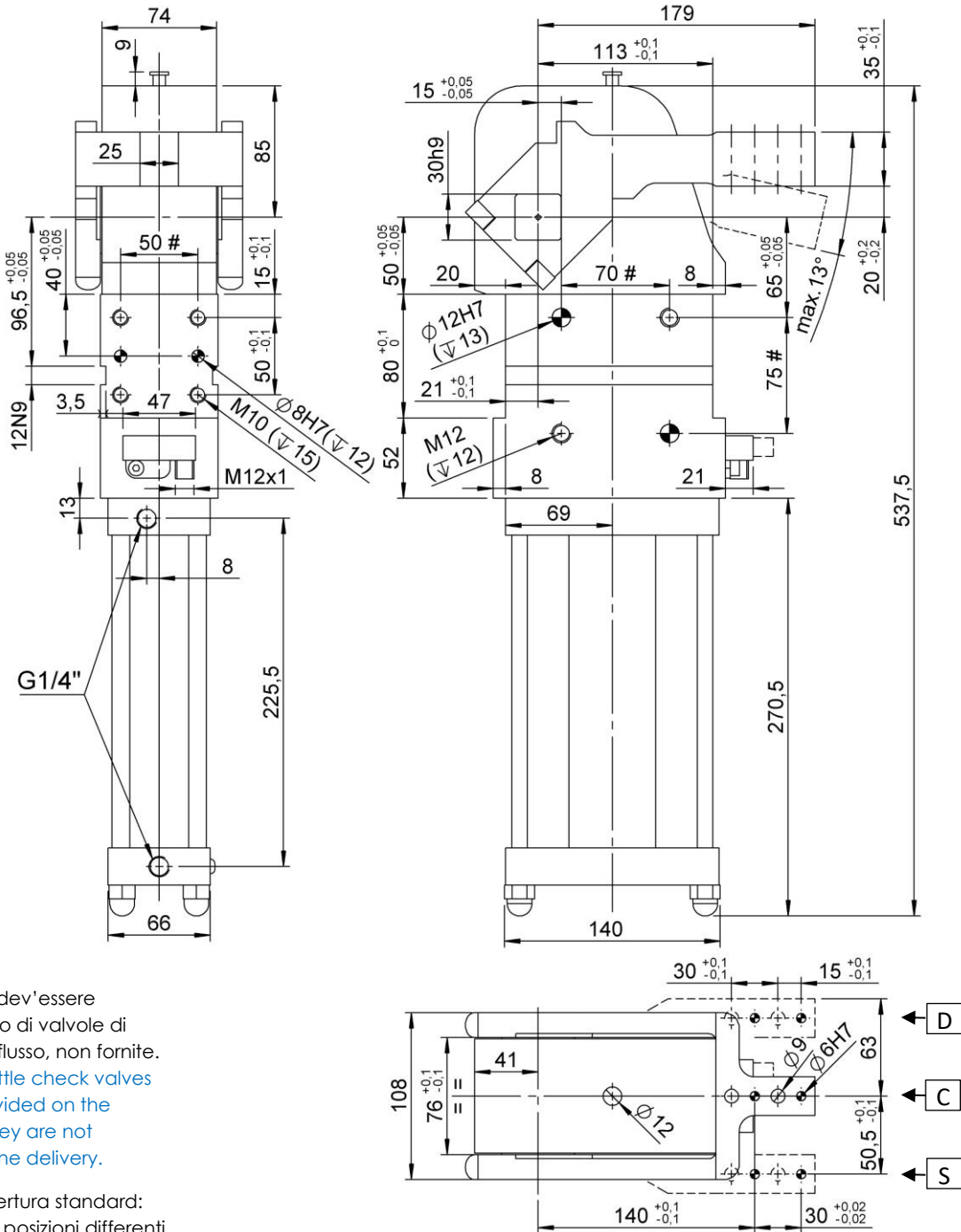

Il dispositivo dev'essere equipaggiato di valvole di regolazione flusso, non fornite.
 External throttle check valves must be provided on the assembly. They are not included in the delivery.

Angoli di apertura standard: settabile in 5 posizioni differenti in un range tra 3° e 13°.

Standard opening angles: settabile in 5 different positions in a range between 3° and 13°.

Tolleranze: fori spina ±0.02, fori filettati ±0.1
 # Tolerances: dowel holes ±0.02, screw holes ±0.1

Modello Type	Alesaggio cilindro Cylinder bore	Momento di ritengo Holding moment	Peso Weight	Pressione d'esercizio Working pressure	Coppia max. di bloccaggio Clamping max. torque (5 bar)	Consumo d'aria max. Max. air consumption (5 bar)
	[mm]	[Nm]	[Kg]	[bar]	[Nm]	[l]
CPL80 V1...S	80	2500	~ 14	4 – 8	1000	4,7



CPL80 H1...S

Chiusura, D.80, Ang. Vario, Leva orizzontale simmetrica, Offset 20
Clamp, D.80, Vario Op. Angle, Horizontal symmetric arm, Offset 20

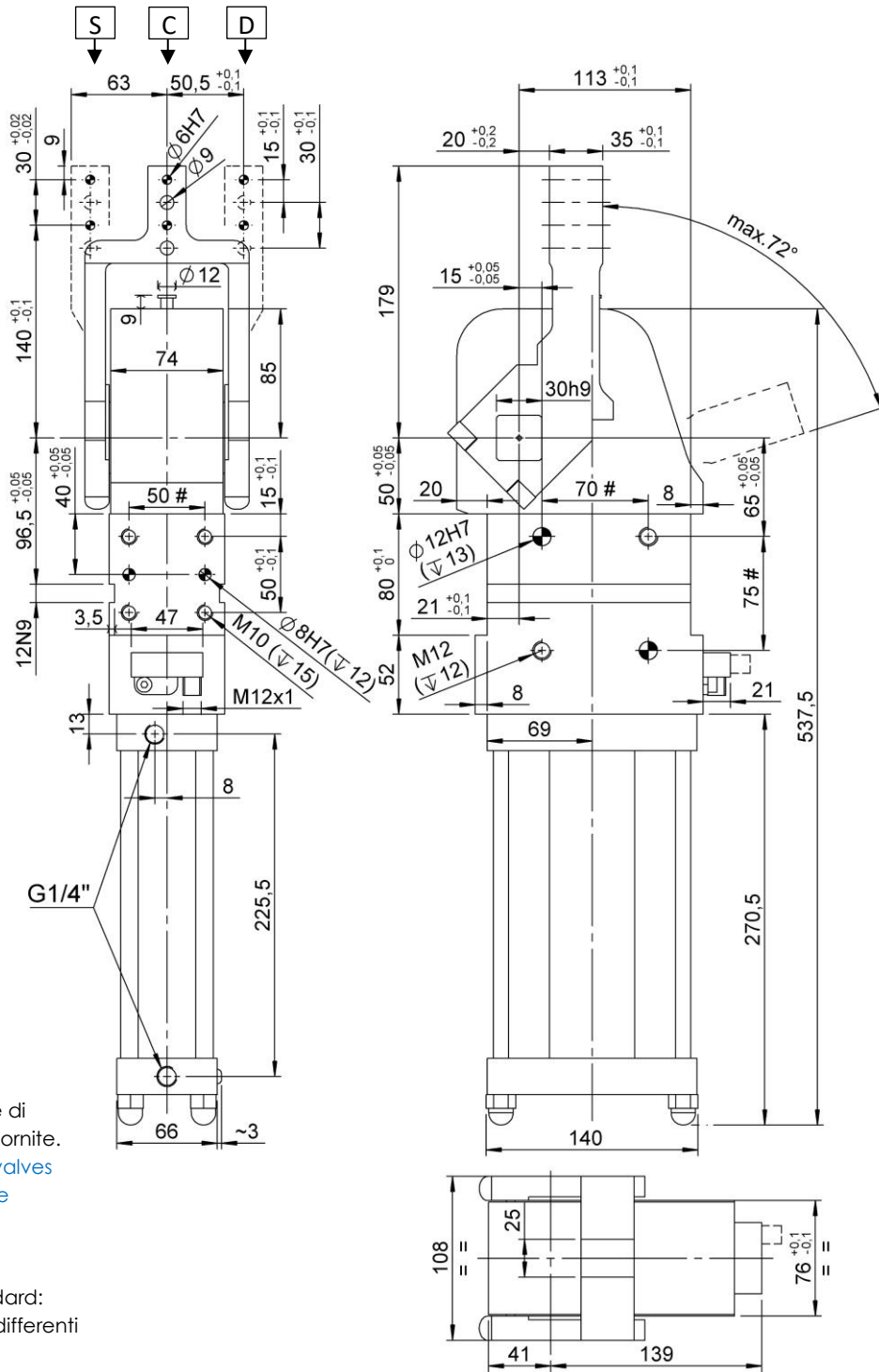

Il dispositivo dev'essere equipaggiato di valvole di regolazione flusso, non fornite.
External throttle check valves must be provided on the assembly. They are not included in the delivery.

Angoli di apertura standard: settabile in 18 posizioni differenti in un range tra 3° e 72°.
Standard opening angles: settabile in 18 different positions in a range between 3° and 72°.

Tolleranze: fori spina ± 0.02 , fori filettati ± 0.1
Tolerances: dowel holes ± 0.02 , screw holes ± 0.1

Modello Type	Alesaggio cilindro Cylinder bore	Momento di ritegno Holding moment	Peso Weight	Pressione d'esercizio Working pressure	Coppia max. di bloccaggio Clamping max. torque (5 bar)	Consumo d'aria max. Max. air consumption (5 bar)
	[mm]	[Nm]	[Kg]	[bar]	[Nm]	[l]
CPL80 H1...S	80	2500	~ 14	4 – 8	1000	6,3



CPL80 V1CDS

Chiusura, D.80, Ang. Vario, Leva CDS verticale, Offset 20
Clamp, D.50, Vario Op. Angle, Vertical CDS arm, Offset 20

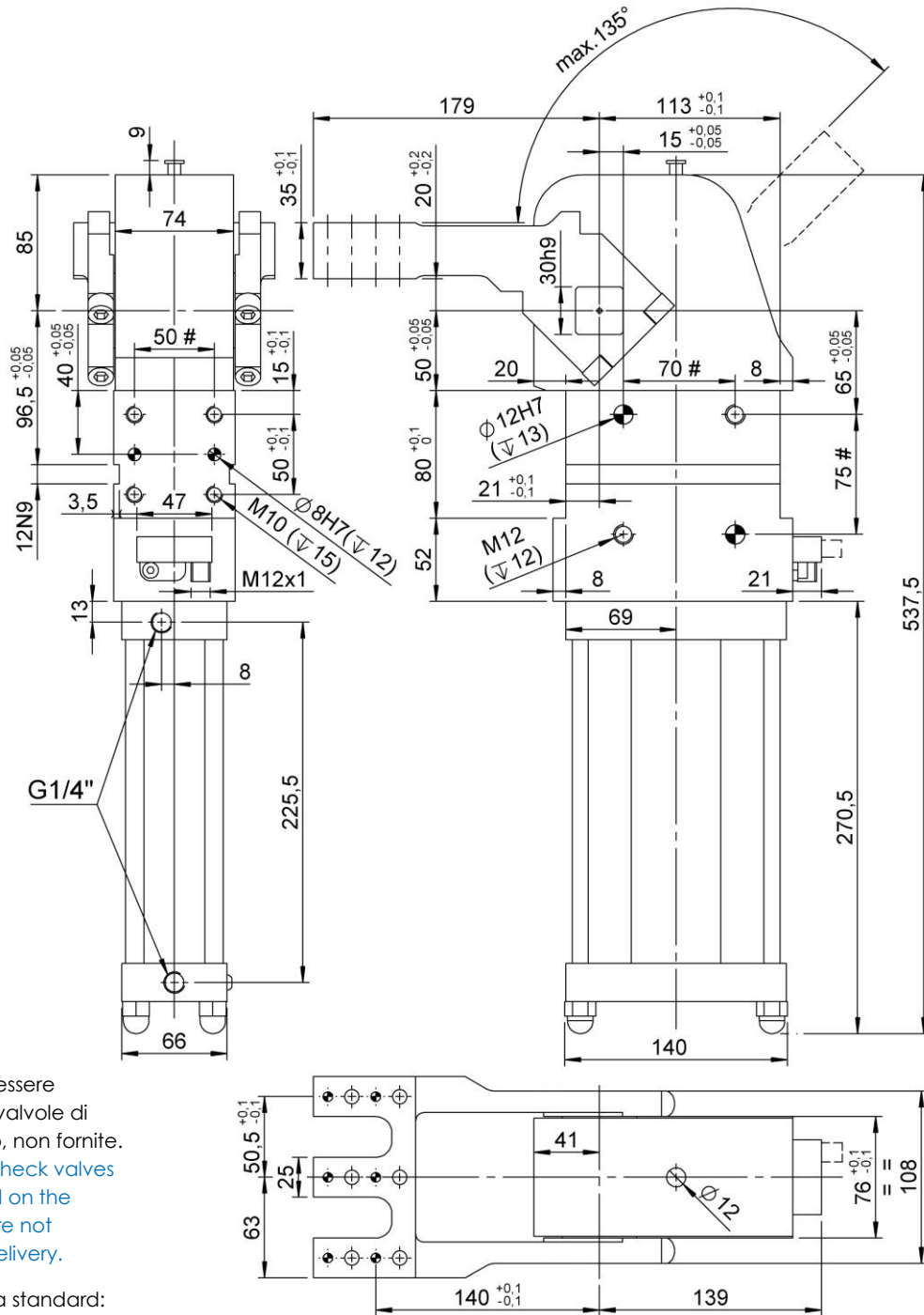

Il dispositivo dev'essere equipaggiato di valvole di regolazione flusso, non fornite.
External throttle check valves must be provided on the assembly. They are not included in the delivery.

Angoli di apertura standard: settabile in 31 posizioni differenti in un range tra 3° e 135°.

Standard opening angles: settabile in 31 different positions in a range between 3° and 135°.

Tolleranze: fori spina ± 0.02 , fori filettati ± 0.1
Tolerances: dowel holes ± 0.02 , screw holes ± 0.1

Modello Type	Alesaggio cilindro Cylinder bore	Momento di ritegno Holding moment	Peso Weight	Pressione d'esercizio Working pressure	Coppia max. di bloccaggio Clamping max. torque (5 bar)	Consumo d'aria max. Max. air consumption (5 bar)
	[mm]	[Nm]	[Kg]	[bar]	[Nm]	[l]
CPL80 V1CDS	80	2500	~ 15	4 – 8	1000	7,9



CPL80 H1CDS

Chiusura, D.80, Ang. Vario, Leva CDS orizzontale, Offset 20
Clamp, D.80, Vario Op. Angle, Horizontal CDS arm, Offset 20

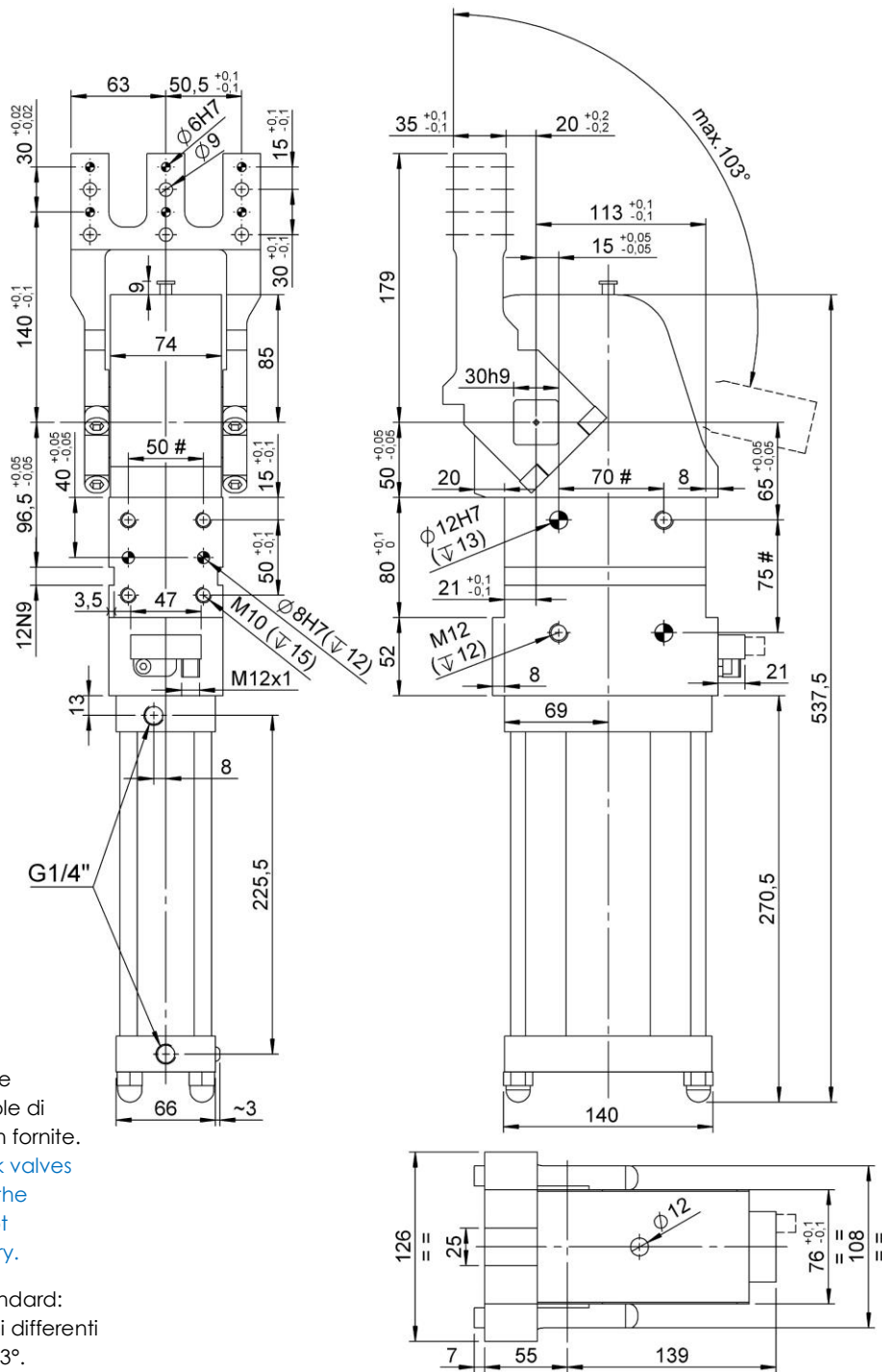

Il dispositivo dev'essere equipaggiato di valvole di regolazione flusso, non fornite.

External throttle check valves must be provided on the assembly. They are not included in the delivery.

Angoli di apertura standard: settabile in 25 posizioni differenti in un range tra 3° e 103°.

Standard opening angles: settabile in 25 different positions in a range between 3° and 103°.

Tolleranze: fori spina ± 0.02 , fori filettati ± 0.1
Tolerances: dowel holes ± 0.02 , screw holes ± 0.1

Modello Type	Alesaggio cilindro Cylinder bore	Momento di ritegno Holding moment	Peso Weight	Pressione d'esercizio Working pressure	Coppia max. di bloccaggio Clamping max. torque (5 bar)	Consumo d'aria max. Max. air consumption (5 bar)
	[mm]	[Nm]	[Kg]	[bar]	[Nm]	[l]
CPL80 H1CDS	80	2500	~ 15	4 – 8	1000	7,1



CPL80 V1CDSS

Chiusura, D.80, Ang. Vario, Leva CDS verticale simmetrica, Offset 20
Clamp, D.80, Vario Op. Angle, Vertical CDS symm. arm, Offset 20

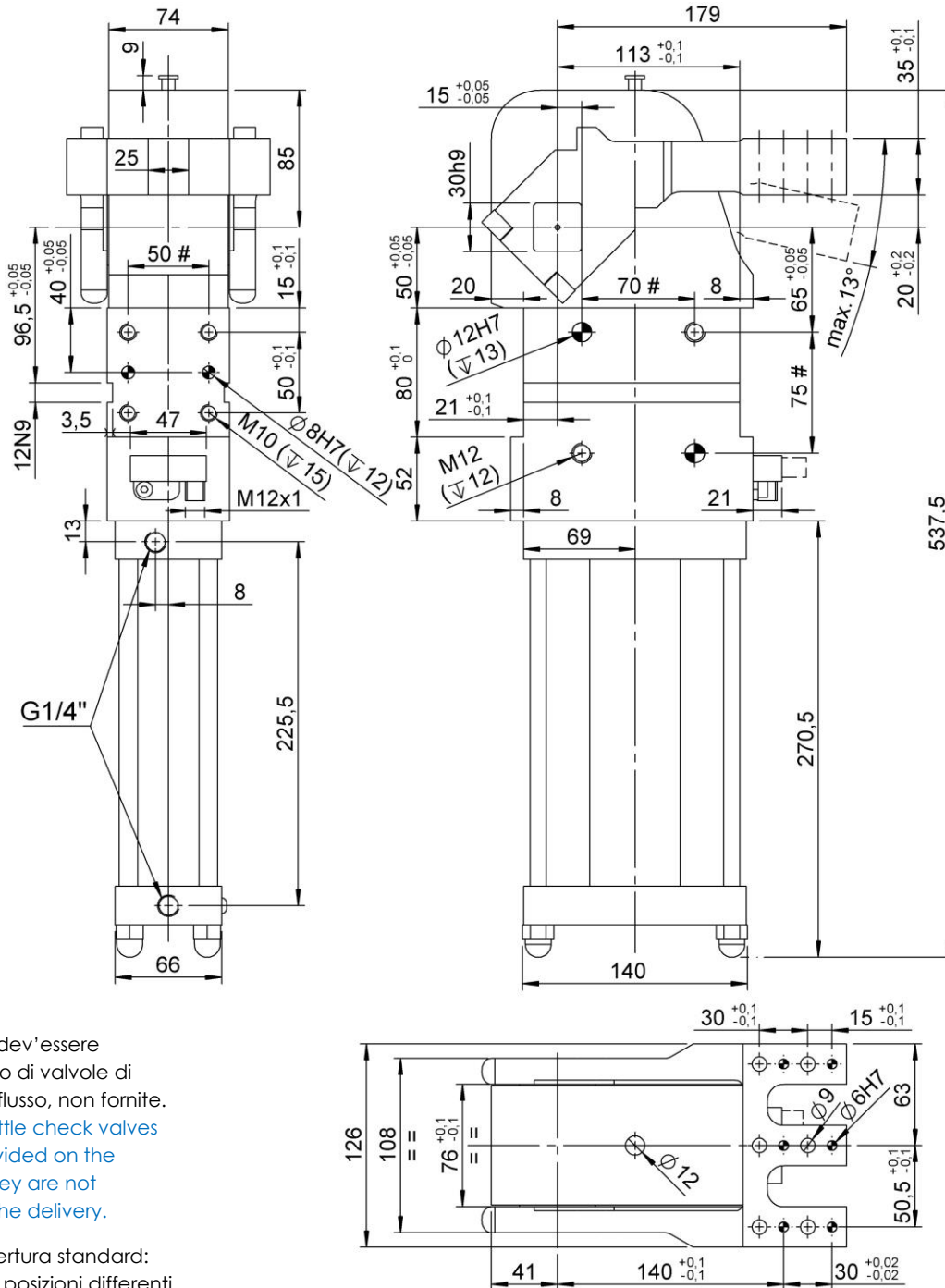

Il dispositivo dev'essere equipaggiato di valvole di regolazione flusso, non fornite.
External throttle check valves must be provided on the assembly. They are not included in the delivery.

Angoli di apertura standard: settabile in 5 posizioni differenti in un range tra 3° e 13°.

Standard opening angles: settabile in 5 different positions in a range between 3° and 13°.

Tolleranze: fori spina ±0.02, fori filettati ±0.1
Tolerances: dowel holes ±0.02, screw holes ±0.1

Modello Type	Alesaggio cilindro Cylinder bore	Momento di ritegno Holding moment	Peso Weight	Pressione d'esercizio Working pressure	Coppia max. di bloccaggio Clamping max. torque (5 bar)	Consumo d'aria max. Max. air consumption (5 bar)
	[mm]	[Nm]	[Kg]	[bar]	[Nm]	[l]
CPL80 V1CDSS	80	2500	~ 15	4 – 8	1000	4,7



CPL80 H1CDSS

Chiusura, D.80, Ang. Vario, Leva CDS orizzontale simm., Offset 20
 Clamp, D.80, Vario Op. Angle, Horizontal CDS symm. arm, Offset 20

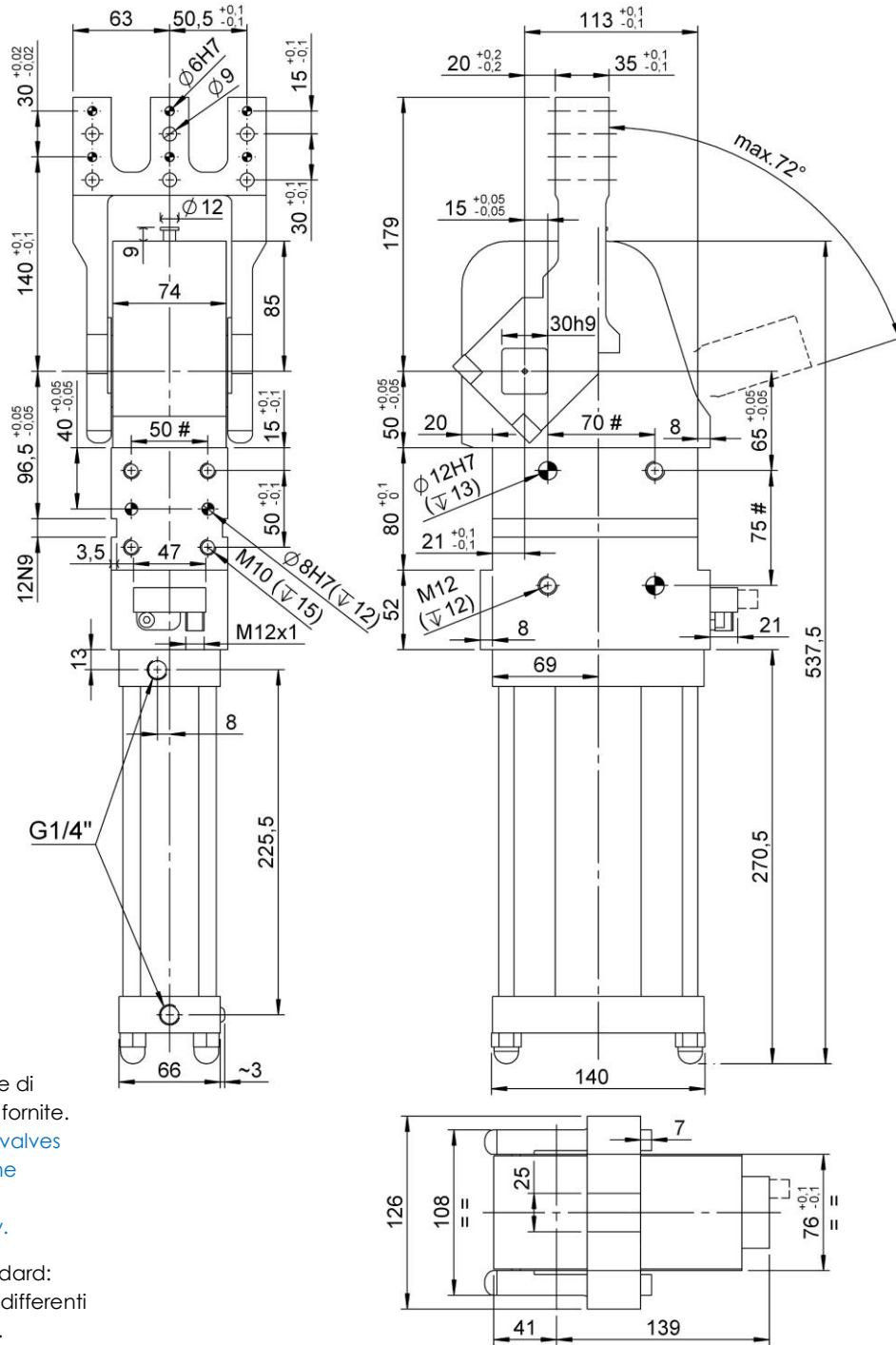

Il dispositivo dev'essere equipaggiato di valvole di regolazione flusso, non fornite.
 External throttle check valves must be provided on the assembly. They are not included in the delivery.

Angoli di apertura standard: settabile in 18 posizioni differenti in un range tra 3° e 72°.

Standard opening angles: settabile in 18 different positions in a range between 3° and 72°.

Tolleranze: fori spina ±0.02, fori filettati ±0.1
 # Tolerances: dowel holes ±0.02, screw holes ±0.1

Modello Type	Alesaggio cilindro Cylinder bore	Momento di ritegno Holding moment	Peso Weight	Pressione d'esercizio Working pressure	Coppia max. di bloccaggio Clamping max. torque (5 bar)	Consumo d'aria max. Max. air consumption (5 bar)
	[mm]	[Nm]	[Kg]	[bar]	[Nm]	[l]
CPL80 H1CDSS	80	2500	~ 15	4 – 8	1000	6,3



CPL80 V3...

Chiusura, D.80, Ang. Vario, Leva verticale, Offset 45
Clamp, D.80, Vario Op. Angle, Vertical arm, Offset 45

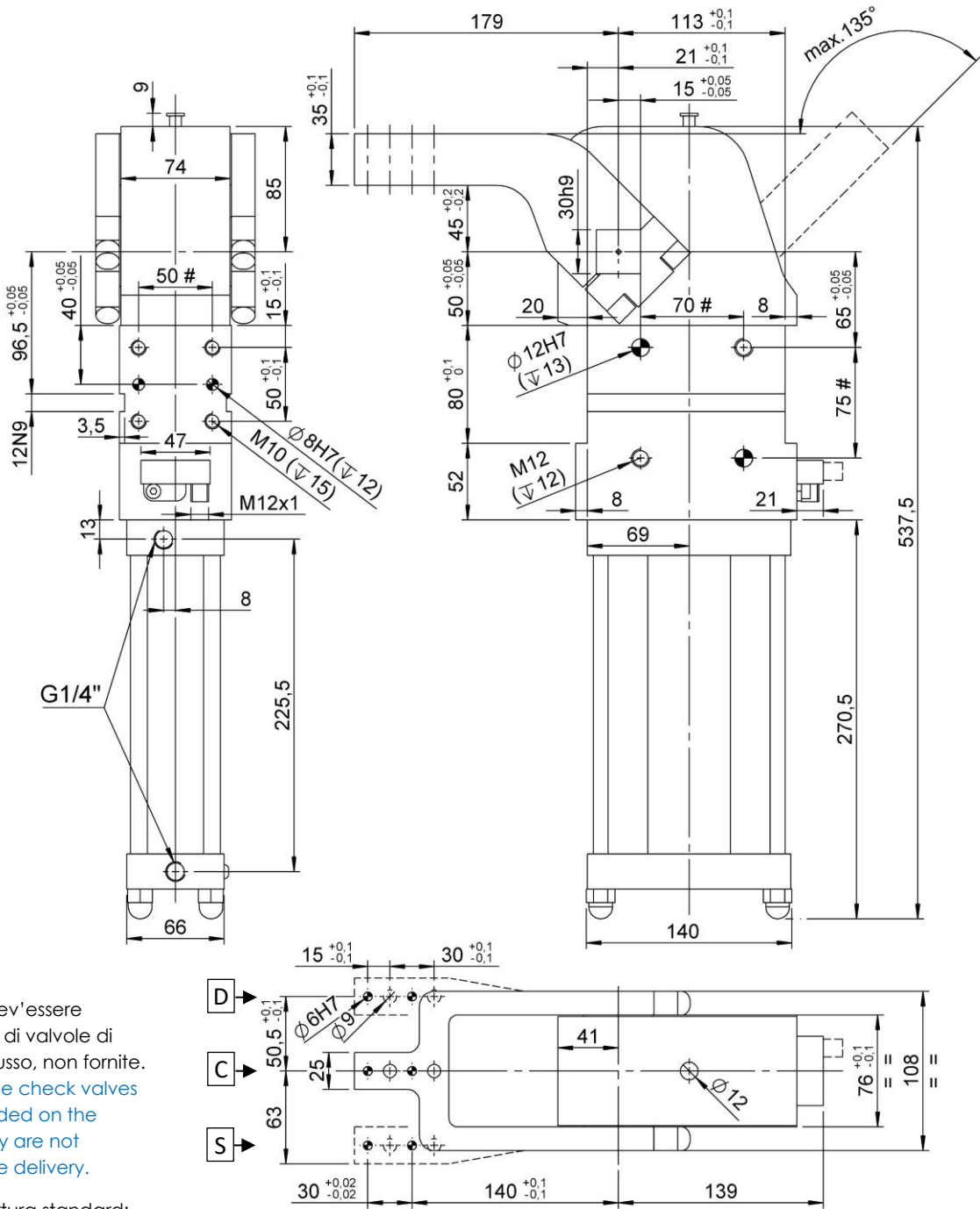

Il dispositivo dev'essere equipaggiato di valvole di regolazione flusso, non fornite.
External throttle check valves must be provided on the assembly. They are not included in the delivery.

Angoli di apertura standard:
settabile in 31 posizioni differenti
in un range tra 3° e 135°.

Standard opening angles:
settabile in 31 different positions
in a range between 3° and 135°.

Tolleranze: fori spina ± 0.02 , fori filettati ± 0.1
Tolerances: dowel holes ± 0.02 , screw holes ± 0.1

Modello Type	Alesaggio cilindro Cylinder bore	Momento di ritegno Holding moment	Peso Weight	Pressione d'esercizio Working pressure	Coppia max. di bloccaggio Clamping max. torque (5 bar)	Consumo d'aria max. Max. air consumption (5 bar)
	[mm]	[Nm]	[Kg]	[bar]	[Nm]	[l]
CPL80 V3...	80	2500	~ 14,5	4 – 8	1000	7,9



CPL80 H3...

Chiusura, D.80, Ang. Vario, Leva orizzontale, Offset 45
Clamp, D.80, Vario Op. Angle, Horizontal arm, Offset 45

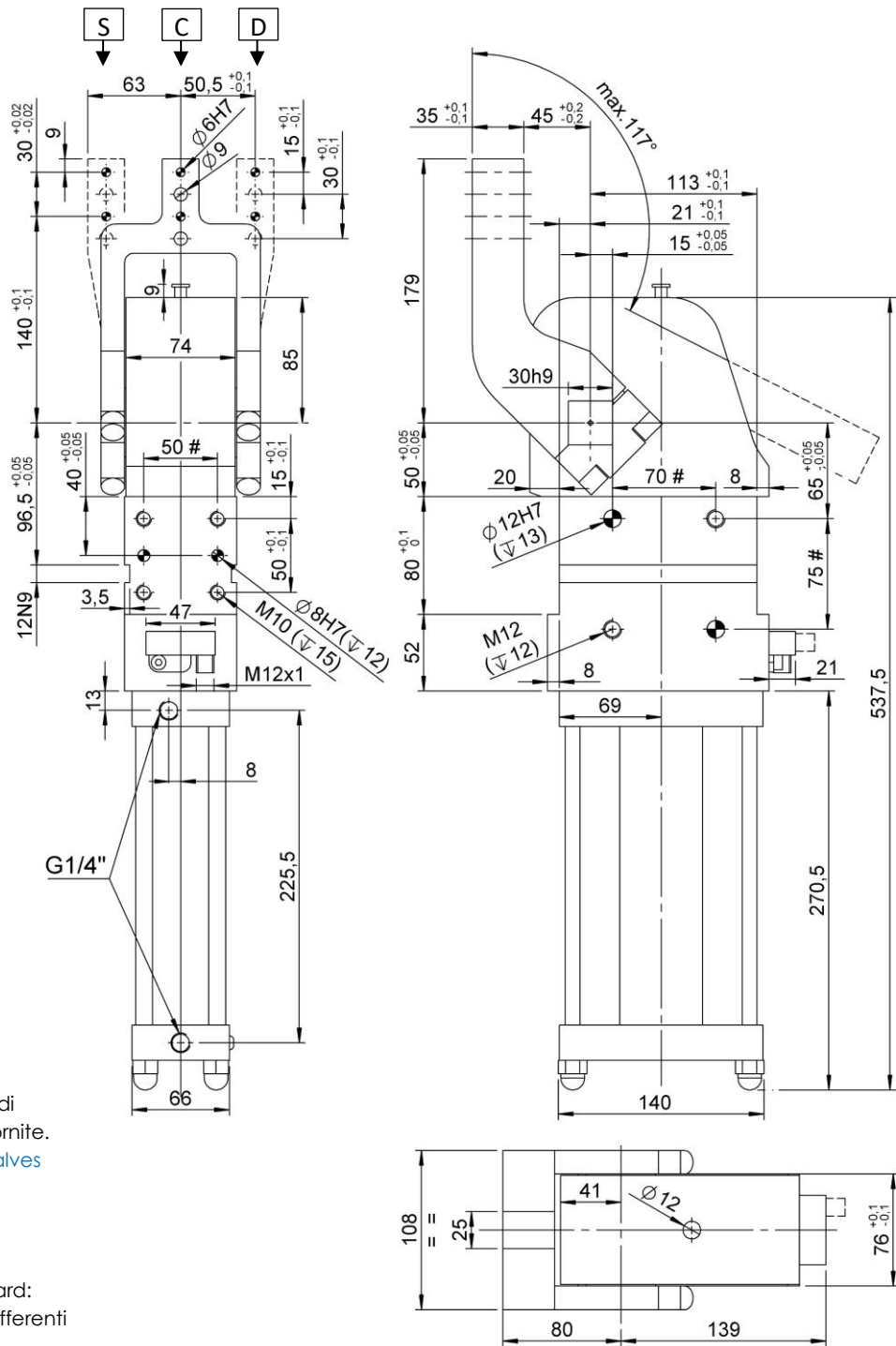

Il dispositivo dev'essere equipaggiato di valvole di regolazione flusso, non fornite.
External throttle check valves must be provided on the assembly. They are not included in the delivery.

Angoli di apertura standard: settabile in 28 posizioni differenti in un range tra 3° e 117°.

Standard opening angles: settabile in 28 differenti posizioni in a range between 3° and 117°.

Tolleranze: fori spina ± 0.02 , fori filettati ± 0.1
Tolerances: dowel holes ± 0.02 , screw holes ± 0.1

Modello Type	Alesaggio cilindro Cylinder bore	Momento di ritegno Holding moment	Peso Weight	Pressione d'esercizio Working pressure	Coppia max. di bloccaggio Clamping max. torque (5 bar)	Consumo d'aria max. Max. air consumption (5 bar)
	[mm]	[Nm]	[Kg]	[bar]	[Nm]	[l]
CPL80 H3...	80	2500	~ 14,5	4 – 8	1000	7,5



CPL80 V3...S

Chiusura, D.80, Ang. Vario, Leva verticale simmetrica, Offset 45
Clamp, D.80, Vario Op. Angle, Vertical symmetric arm, Offset 45

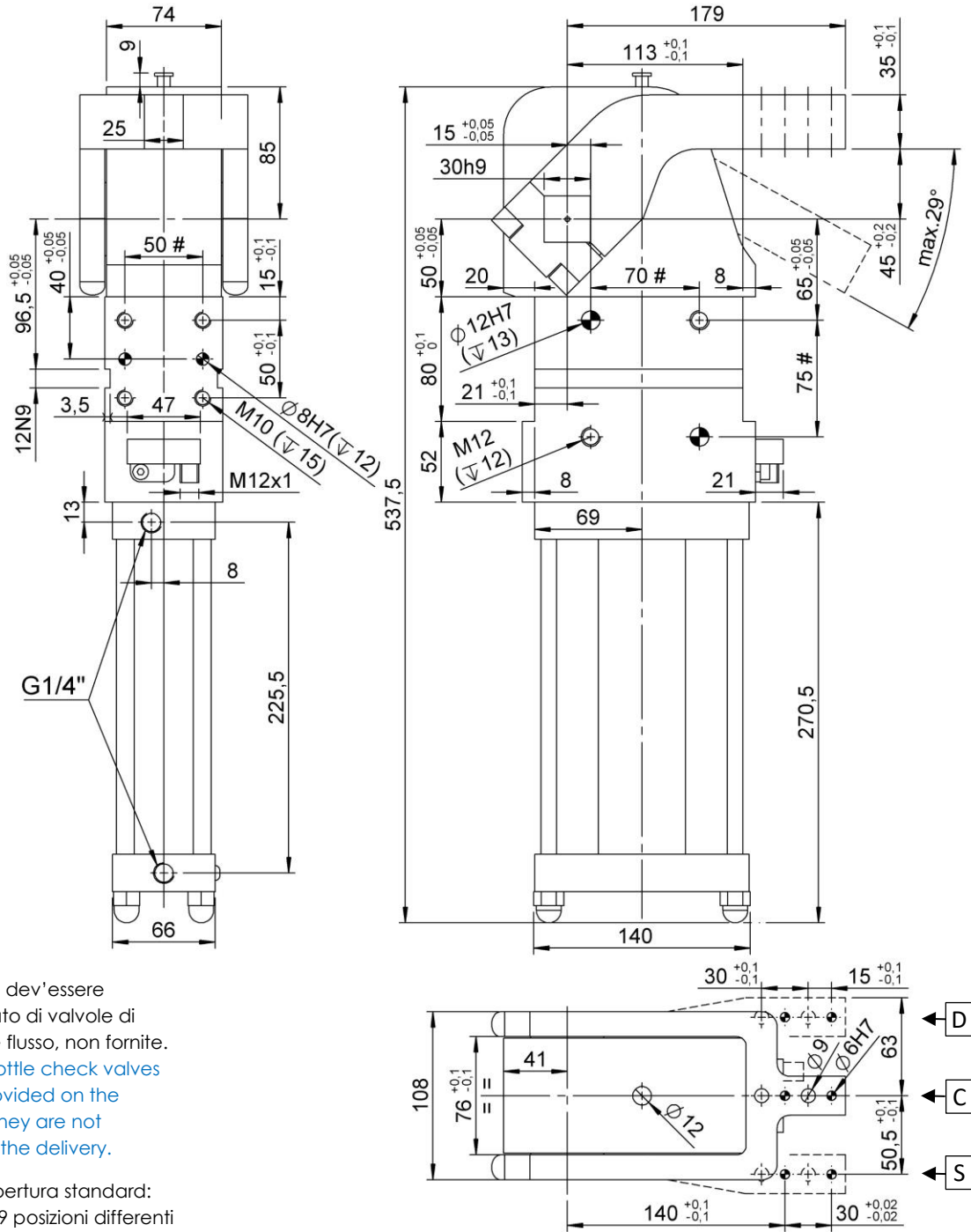

Il dispositivo dev'essere equipaggiato di valvole di regolazione flusso, non fornite.
External throttle check valves must be provided on the assembly. They are not included in the delivery.

Angoli di apertura standard: settabile in 9 posizioni differenti in un range tra 3° e 29°.

Standard opening angles: settabile in 7 different positions in a range between 3° and 29°.

Tolleranze: fori spina ± 0.02 , fori filettati ± 0.1
Tolerances: dowel holes ± 0.02 , screw holes ± 0.1

Modello Type	Alesaggio cilindro Cylinder bore	Momento di ritegno Holding moment	Peso Weight	Pressione d'esercizio Working pressure	Coppia max. di bloccaggio Clamping max. torque (5 bar)	Consumo d'aria Air consumption (5 bar)
	[mm]	[Nm]	[Kg]	[bar]	[Nm]	[l]
CPL80 V3...S	80	2500	~ 14,5	4 – 8	1000	5,2



CPL80 H3...S

Chiusura, D.80, Ang. Vario, Leva orizzontale simmetrica, Offset 45
Clamp, D.80, Vario Op. Angle, Horizontal symmetric arm, Offset 45

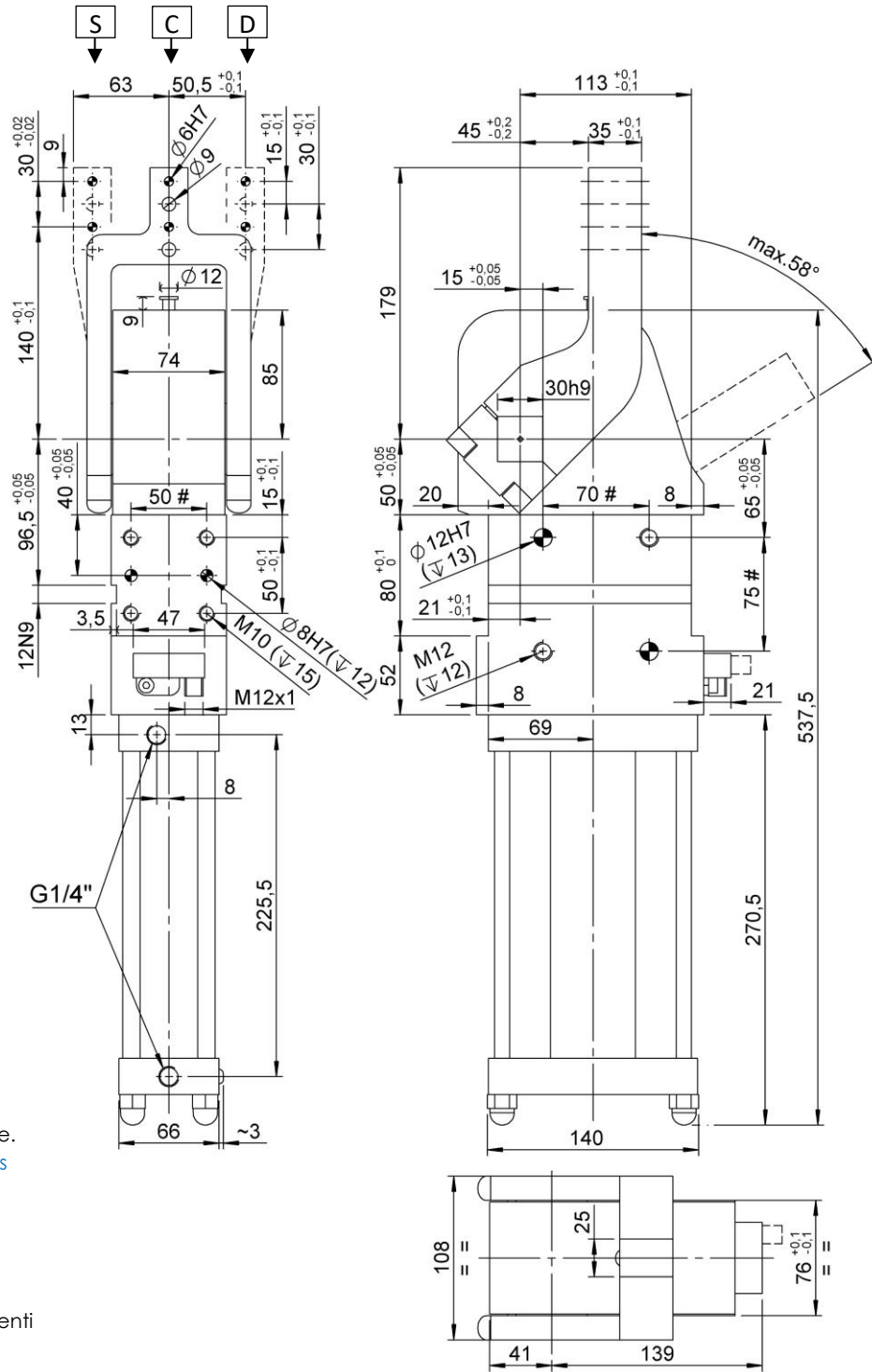

Il dispositivo dev'essere equipaggiato di valvole di regolazione flusso, non fornite.
External throttle check valves must be provided on the assembly. They are not included in the delivery.

Angoli di apertura standard: settabile in 15 posizioni differenti in un range tra 3° e 58°.
Standard opening angles: settabile in 15 different positions in a range between 3° and 58°.

Tolleranze: fori spina ± 0.02 , fori filettati ± 0.1
Tolerances: dowel holes ± 0.02 , screw holes ± 0.1

Modello Type	Alesaggio cilindro Cylinder bore	Momento di ritegno Holding moment	Peso Weight	Pressione d'esercizio Working pressure	Coppia max. di bloccaggio Clamping max. torque (5 bar)	Consumo d'aria Air consumption (5 bar)
	[mm]	[Nm]	[Kg]	[bar]	[Nm]	[l]
CPL80 H3...S	80	2500	~ 14,5	4 – 8	1000	5,9



CPLM80L...V1...

Chiusura, D.80, Ang. Vario, Cmd. Manuale, Leva Vert, Offset 20
Clamp, D.80, Vario Op. Angle, Hand Lever, Vert. arm, Offset 20

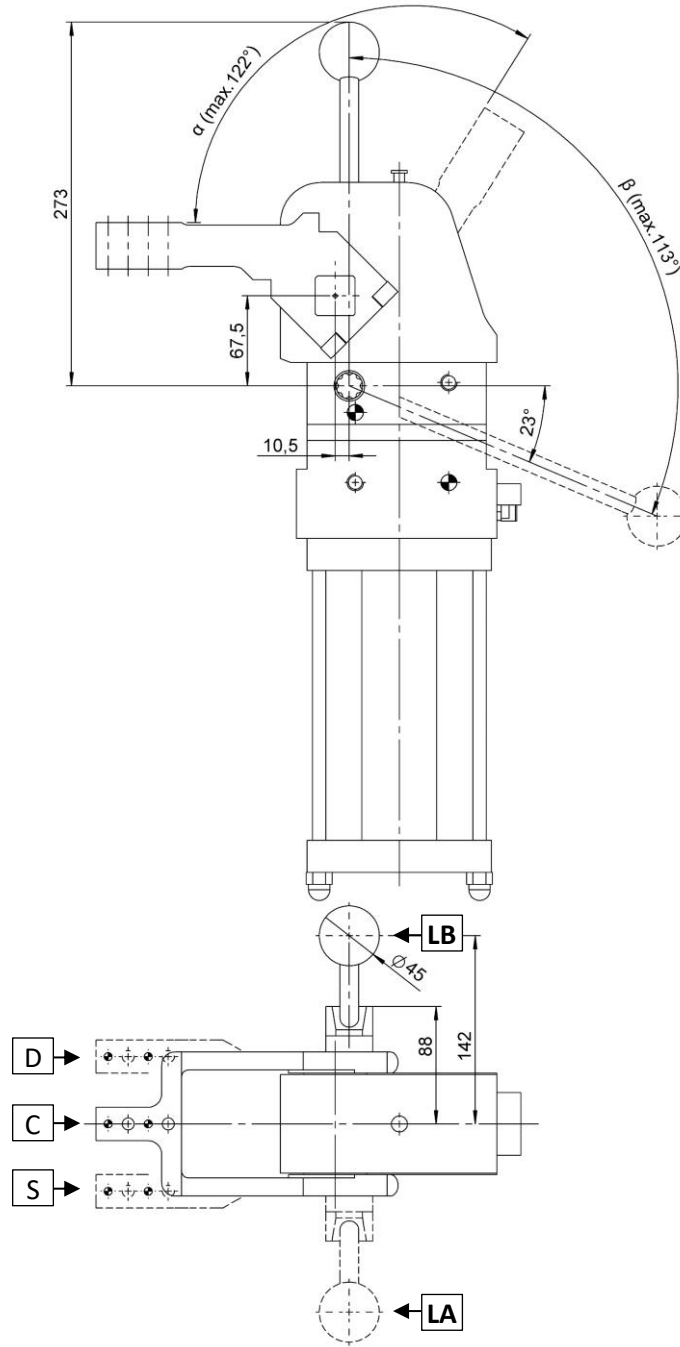

α	16°	29°	43°	58°	77°	90°	107°	122°
β	37°	46°	55°	64°	76°	86°	100°	113°

Leva comando manuale orientabile ad intervalli di 22,5°
Manual control adjustable in steps of 22,5°

Tolleranze: fori spina ± 0.02 , fori filettati ± 0.1
Tolerances: dowel holes ± 0.02 , screw holes ± 0.1

Modello Type	Alesaggio cilindro Cylinder bore	Momento di ritegno Holding moment	Peso Weight	Pressione d'esercizio Working pressure	Max. forza manuale applicabile Max. manual force
	[mm]	[Nm]	[Kg]	[bar]	[N]
CPLM80L...V1...	80	2500	~ 16	4 - 8	200



CPLM80L...H1...

Chiusura, D.80, Ang. Vario, Cmd. Manuale, Leva Orizz., Offset 20
Clamp, D.80, Vario Op. Angle, Hand Lever, Horiz. Arm, Offset 20

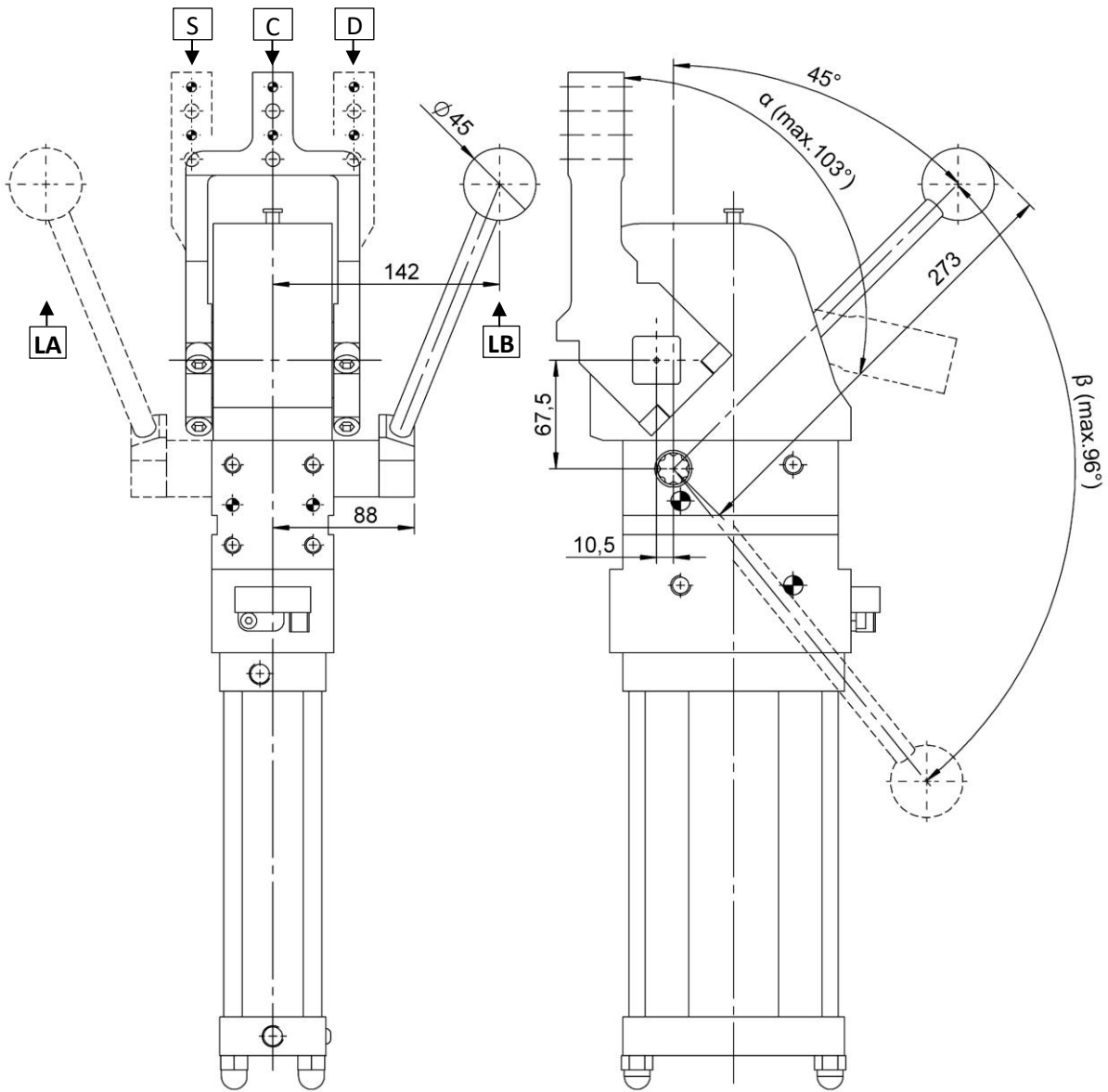

α	16°	29°	43°	58°	77°	90°	103°
β	37°	46°	55°	64°	76°	86°	96°

Leva comando manuale orientabile ad intervalli di 22,5°
Manual control adjustable in steps of 22,5°

Tolleranze: fori spina ± 0.02 , fori filettati ± 0.1
Tolerances: dowel holes ± 0.02 , screw holes ± 0.1

Modello Type	Alesaggio cilindro Cylinder bore	Momento di ritegno Holding moment	Peso Weight	Pressione d'esercizio Working pressure	Max. forza manuale applicabile Max. manual force
	[mm]	[Nm]	[Kg]	[bar]	[N]
CPLM80L...H1...	80	2500	~ 16	4 - 8	200



CPLM80L...V1...S

Chiusura, D.80, Ang. Vario, Cmd. Manuale, Vert. Sim., Offset 20
 Clamp, D.80, Vario Op. Angle, Hand Lever, Vert. Sym., Offset 20

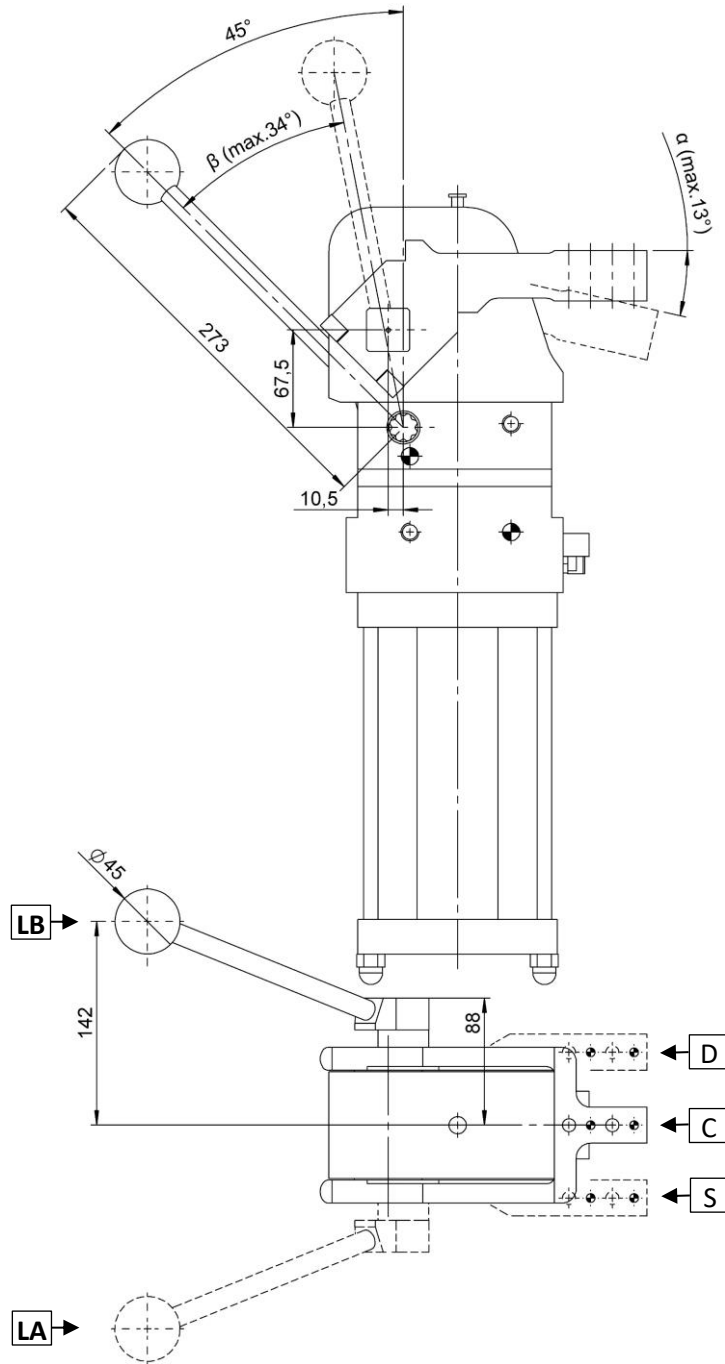

α	13°
β	34°

Leva comando manuale orientabile ad intervalli di 22,5°
 Manual control adjustable in steps of 22,5°

Tolleranze: fori spina ± 0.02 , fori filettati ± 0.1
 # Tolerances: dowel holes ± 0.02 , screw holes ± 0.1

Modello Type	Alesaggio cilindro Cylinder bore	Momento di ritegno Holding moment	Peso Weight	Pressione d'esercizio Working pressure	Max. forza manuale applicabile Max. manual force
	[mm]	[Nm]	[Kg]	[bar]	[N]
CPLM80L...V1...S	80	2500	~ 16	4 – 8	200



CPLM80L...H1...S

Chiusura, D.80, Ang. Vario, Cmd. Manuale, Orizz. Sim., Offset 20
 Clamp, D.80, Vario Op. Angle, Hand Lever, Horiz. Sym., Offset 20

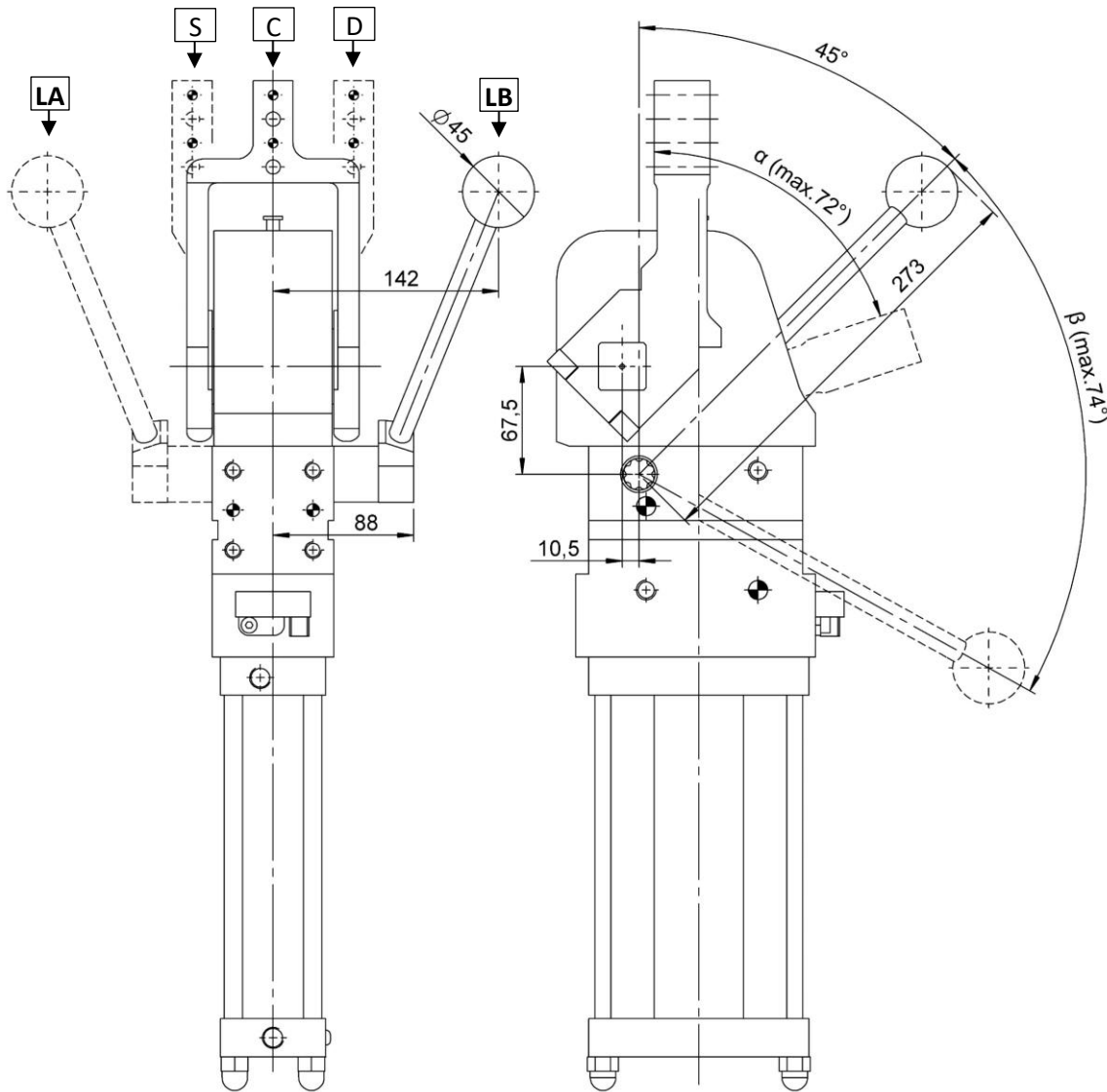

α	16°	30°	46°	58°	72°
β	37°	47°	57°	63°	74°

Leva comando manuale orientabile ad intervalli di 22,5°
 Manual control adjustable in steps of 22,5°

Tolleranze: fori spina ± 0.02 , fori filettati ± 0.1
 # Tolerances: dowel holes ± 0.02 , screw holes ± 0.1

Modello Type	Alesaggio cilindro Cylinder bore	Momento di ritegno Holding moment	Peso Weight	Pressione d'esercizio Working pressure	Max. forza manuale applicabile Max. manual force
	[mm]	[Nm]	[Kg]	[bar]	[N]
CPLM80L...H1...S	80	2500	~ 16	4 - 8	200



CPLM80L...V3...

Chiusura, D.80, Ang. Vario, Cmd. Manuale, Leva Vert, Offset 45
Clamp, D.80, Vario Op. Angle, Hand Lever, Vert. arm, Offset 45

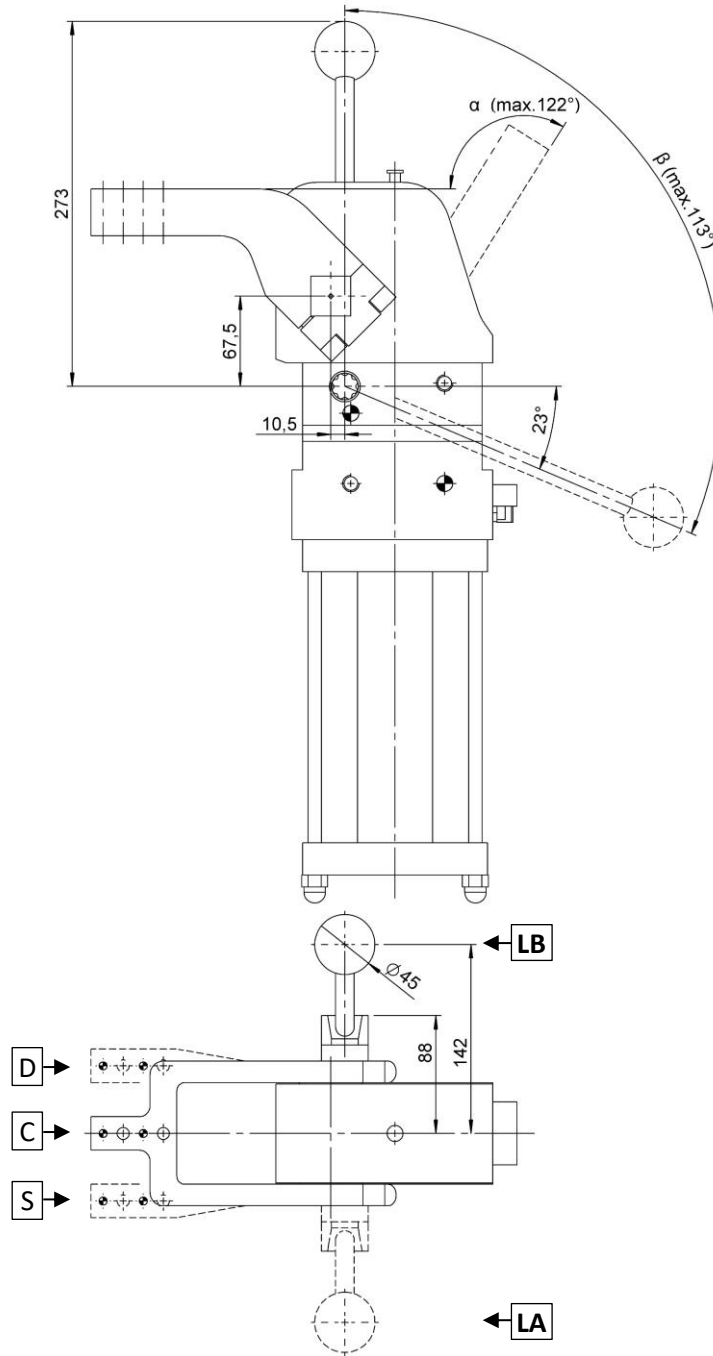

α	16°	29°	43°	58°	77°	90°	107°	122°
β	37°	46°	55°	64°	76°	86°	100°	113°

Leva comando manuale orientabile ad intervalli di 22,5°
Manual control adjustable in steps of 22,5°

Tolleranze: fori spina ± 0.02 , fori filettati ± 0.1
Tolerances: dowel holes ± 0.02 , screw holes ± 0.1

Modello Type	Alesaggio cilindro Cylinder bore	Momento di ritegno Holding moment	Peso Weight	Pressione d'esercizio Working pressure	Max. forza manuale applicabile Max. manual force
	[mm]	[Nm]	[Kg]	[bar]	[N]
CPLM80L...V3...	80	2500	~ 16,5	4 - 8	200



CPLM80L...H3...

Chiusura, D.80, Ang. Vario, Cmd. Manuale, Leva Orizz., Offset 45
Clamp, D.80, Vario Op. Angle, Hand Lever, Horiz. Arm, Offset 45

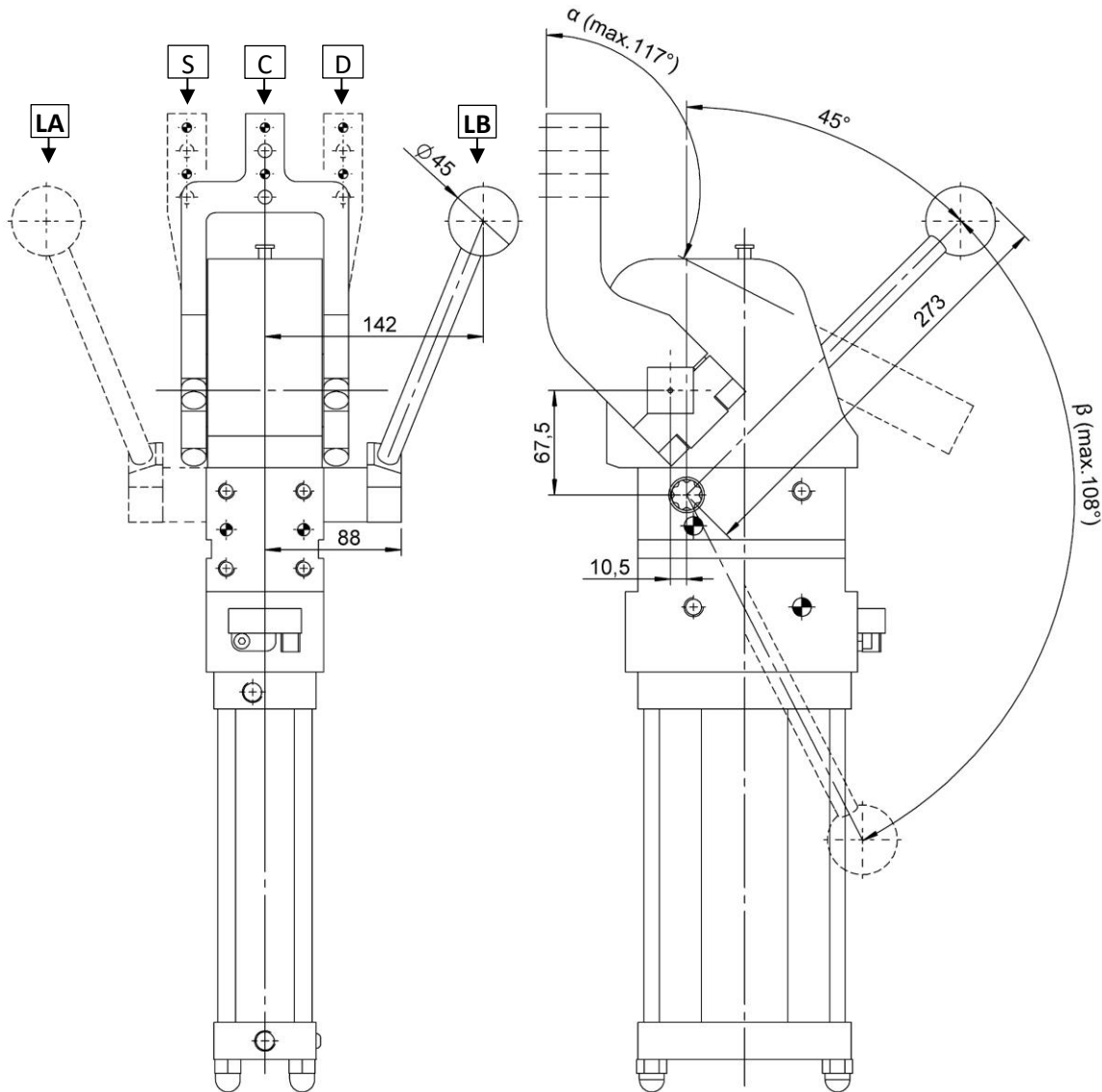

α	16°	29°	43°	58°	77°	90°	107°	117°
β	37°	46°	55°	64°	76°	86°	100°	108°

Leva comando manuale orientabile ad intervalli di 22,5°
Manual control adjustable in steps of 22,5°

Tolleranze: fori spina ± 0.02 , fori filettati ± 0.1
Tolerances: dowel holes ± 0.02 , screw holes ± 0.1

Modello Type	Alesaggio cilindro Cylinder bore	Momento di ritegno Holding moment	Peso Weight	Pressione d'esercizio Working pressure	Max. forza manuale applicabile Max. manual force
	[mm]	[Nm]	[Kg]	[bar]	[N]
CPLM80L...H3...	80	2500	~ 16,5	4 - 8	200



CPLM80L...V3...S

Chiusura, D.80, Ang. Vario, Cmd. Manuale, Vert. Sim., Offset 45
 Clamp, D.80, Vario Op. Angle, Hand Lever, Vert. Sym., Offset 45

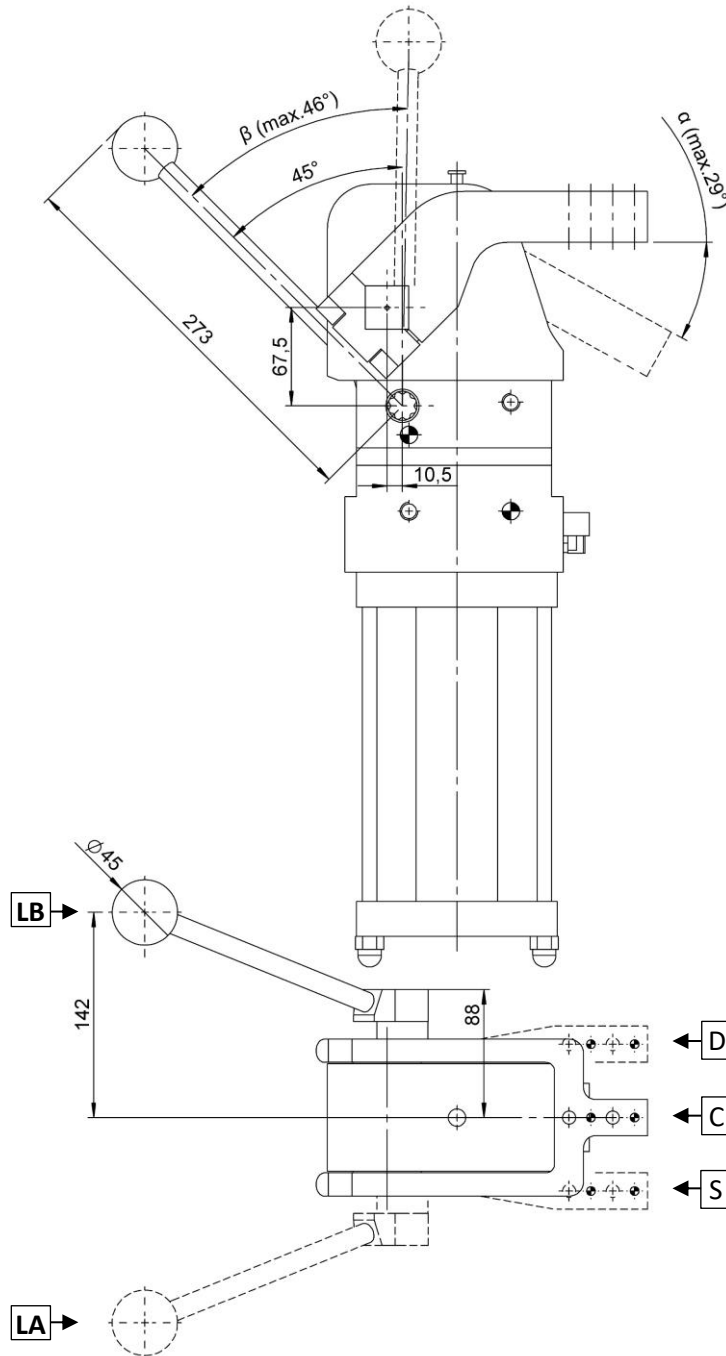

α	16°	29°
β	37°	46°

Leva comando manuale orientabile ad intervalli di 22,5°
 Manual control adjustable in steps of 22,5°

Tolleranze: fori spina ± 0.02 , fori filettati ± 0.1
 # Tolerances: dowel holes ± 0.02 , screw holes ± 0.1

Modello Type	Alesaggio cilindro Cylinder bore	Momento di ritegno Holding moment	Peso Weight	Pressione d'esercizio Working pressure	Max. forza manuale applicabile Max. manual force
	[mm]	[Nm]	[Kg]	[bar]	[N]
CPLM50L...V3...S	80	2500	~ 16,5	4 – 8	200



CPLM80L...H3...S

Chiusura, D.80, Ang. Vario, Cmd. Manuale, Orizz. Sim., Offset 45
 Clamp, D.80, Vario Op. Angle, Hand Lever, Horiz. Sym., Offset 45

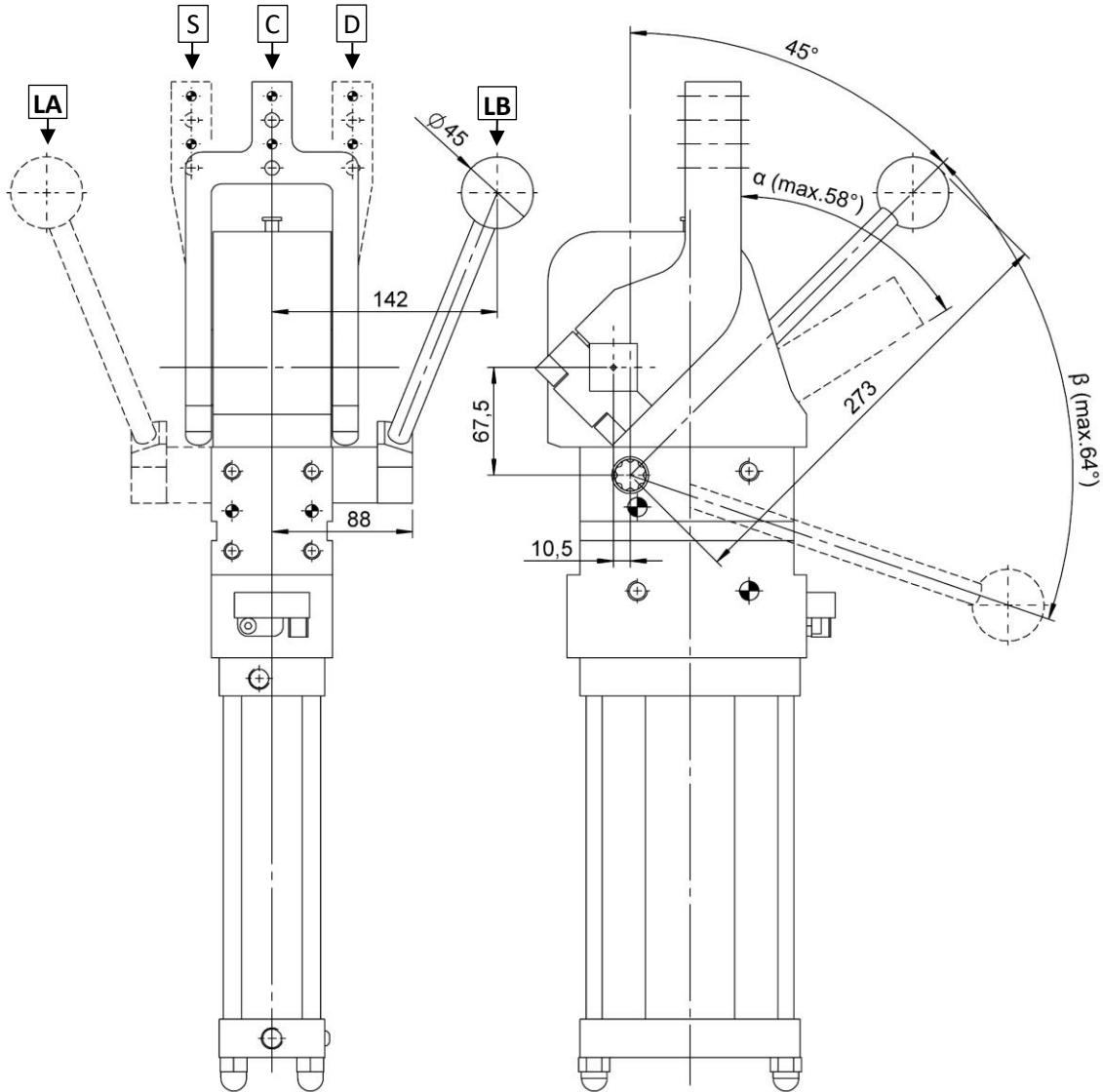

α	16°	29°	43°	58°
β	37°	46°	55°	64°

Leva comando manuale orientabile ad intervalli di 22,5°
 Manual control adjustable in steps of 22,5°

Tolleranze: fori spina ± 0.02 , fori filettati ± 0.1
 # Tolerances: dowel holes ± 0.02 , screw holes ± 0.1

Modello Type	Alesaggio cilindro Cylinder bore	Momento di ritegno Holding moment	Peso Weight	Pressione d'esercizio Working pressure	Max. forza manuale applicabile Max. manual force
	[mm]	[Nm]	[Kg]	[bar]	[N]
CPLM80L...H3...S	80	2500	~ 16,5	4 – 8	200



Diagrammi CPL80.

Diagrams CPL80.

Coppia di bloccaggio (Nm)

Clamping torque (Nm)

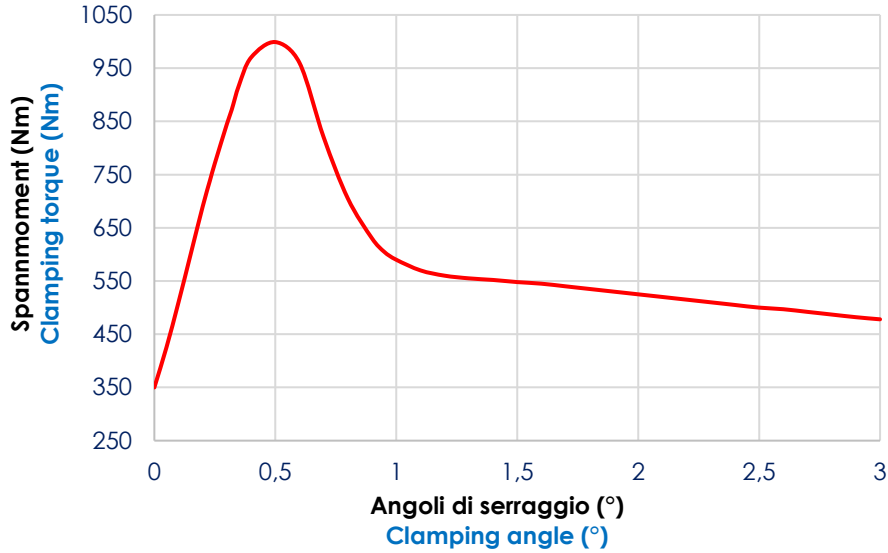

Coppia max. di bloccaggio (5 bar): **1000 Nm.**

Max. clamping torque (5 bar): **1000 Nm.**

Carico max. applicabile alla leva (Kg) a 5 bar.

Max. load applicable on the arm (Kg) at 5 bar.

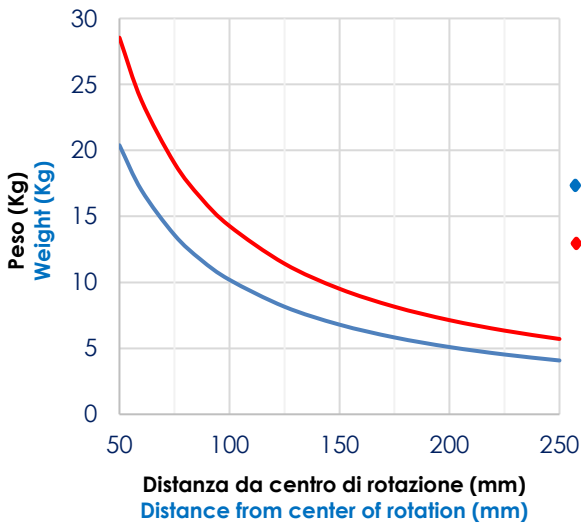

Forza max. esercitata (N) a 5 bar.

Max. force applied (N) at 5 bar.

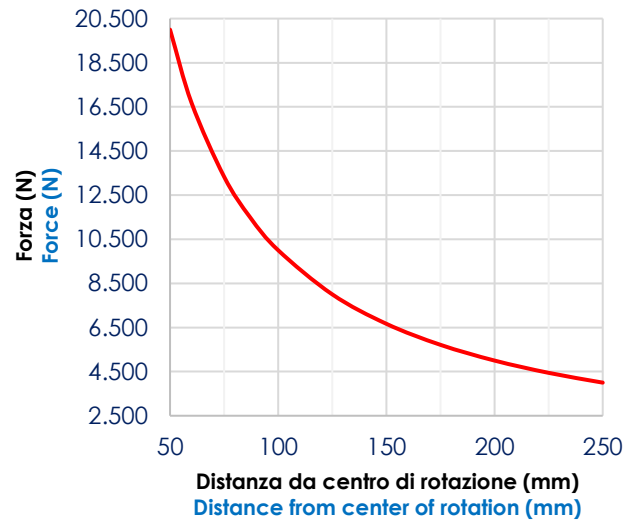

Modello Type	Coppia max. dal peso Max. torque By weight [Nm]		Coppia max. con tassello fuori asse The max torque for applications with the load out of axis [Nm]	
	1 sec	2 sec	1 sec	2 sec
CPL 80	10	14	7,5	10,5



Schema Finecorsa induttivo M12 (cod. 09960/L/C).

Diagram for M12 inductive proximity switch (cod. 09960/L/C).

Caratteristiche tecniche:

- Tipo di uscita: PNP;
- Tensione d'alimentazione: 10-30 VDC;
- Corrente max. di commutazione: 150 mA;
- Consumo di corrente: < 20 mA;
- Calo di tensione: < 1,8 V
- Campo di temperatura: -25° / 70° C.

Technical data:

- Output type: PNP;
- Feeding voltage: 10-30 VDC;
- Max. commutating current: 150 mA;
- Power supply: < 20 mA;
- Voltage drop: < 1,8 V;
- Temperature range: -25° / 70° C.

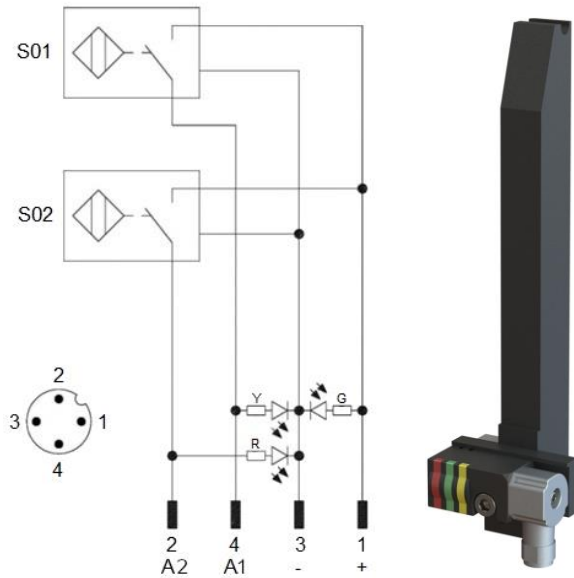

S01 = segnale d'apertura
 S01 = opening signal
 S02 = segnale di chiusura
 S02 = closing signal

Y = LED giallo / yellow LED
 G = LED verde / green LED
 R = LED rosso / red LED

1 = filo marrone / brown wire
 2 = filo nero / black wire
 3 = filo blu / blue wire
 4 = filo bianco / white wire

Schema pneumatico.

Pneumatic plan.

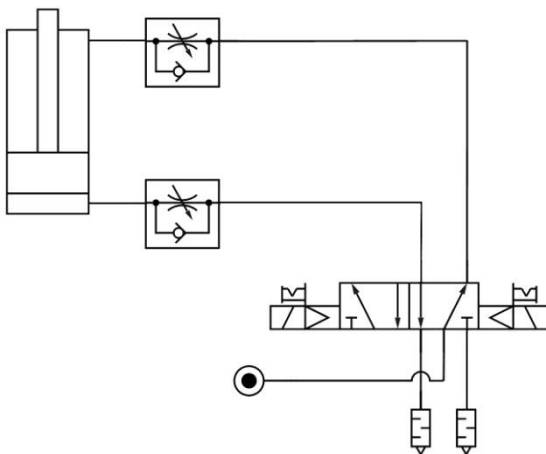

cilindro pneumatico pneumatic cylinder	pos. chiusura closed pos.						
	pos. apertura open pos.						
segnale pos. apertura open pos. signal	1						
	0						
segnale pos. chiusura closed pos. signal	1						
	0						



Istruzioni operative.

Operating instructions.

Modifica angolo d'apertura.

- Portare la leva in posizione di apertura e svitare la vite M6 che fissa il sensore induttivo; (Imm. 1)
- Seguire uno dei seguenti metodi per modificare l'angolo d'apertura:
 - 1) Portare una vite M6 di lunghezza min. 40mm a contatto con l'innesto dentato, ed avvitare finchè il sistema non si libera (~ 4 giri) ; (Imm. 2)
 - 2) Inserire nel foro una chiave con Ø max. di 5mm, e spingere la molla applicando una forza ≥ 200 N; (Imm. 3)
- Mantenere la spinta sulla molla e spostare manualmente la leva nella posizione desiderata;
- Rilasciare il sistema a molla per permettere l'aggancio automatico dei componenti.
- Per l'assemblaggio seguire la procedura sopra descritta in senso contrario.

Opening angle change.

- Bring the clamp arm in the opening position and unscrew the M6 bolt that fixes the sensor; (pic 1)
- Follow one of the following methods to change the opening angle:
 - 1) Bring a M6 screw of min.40mm in contact with the toothed coupling and screw it until the system is released (~4 turns); (pic 2)
 - 2) Put a key with Ø max.5 mm into the hole, and push the spring applying a force ≥ 200 N; (pic 3)
- Keep pushing on the spring and move the clamp arm manually to the desired position.
- Release the spring to allow the automatic coupling of the components.
- for assembly follow the procedure described above in reverse order.



Immagine 1
Pic 1



Immagine 2
Pic 2

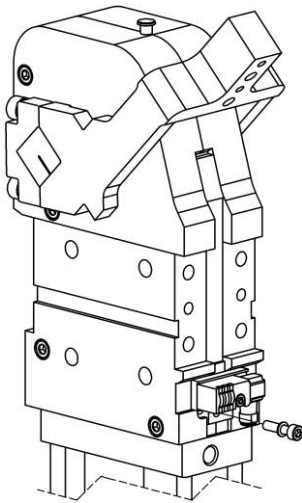

Immagine 3
Pic 3

Angoli d'apertura.

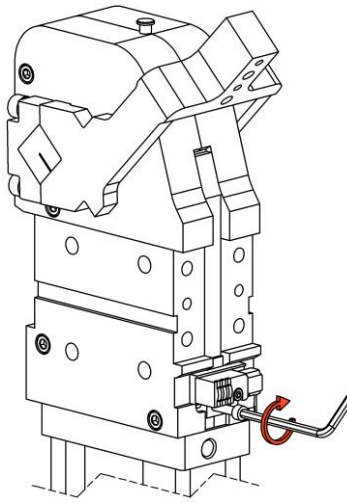
Opening angles.

Tipo Type	Angoli d'apertura / Opening angles																															
	3	5	7	10	13	16	20	24	29	33	38	43	48	53	58	63	68	72	77	81	86	90	95	99	103	107	112	117	122	127	135	
CPL...V1 CPL...V3	•	•	•	•	•	•	•	•	•	•	•	•	•	•	•	•	•	•	•	•	•	•	•	•	•	•	•	•	•	•	•	•
CPL...H1	•	•	•	•	•	•	•	•	•	•	•	•	•	•	•	•	•	•	•	•	•	•	•	•	•	•	•	•	•	•	•	•
CPL...H3	•	•	•	•	•	•	•	•	•	•	•	•	•	•	•	•	•	•	•	•	•	•	•	•	•	•	•	•	•	•	•	•
CPL...V1...S	•	•	•	•	•																											
CPLV3...S	•	•	•	•	•	•	•	•																								
CPL...H1...S	•	•	•	•	•	•	•	•	•	•	•	•	•	•	•	•	•	•	•	•	•	•	•	•	•	•	•	•	•	•	•	•
CPL...H3...S	•	•	•	•	•	•	•	•	•	•	•	•	•	•	•	•	•	•	•	•	•	•	•	•	•	•	•	•	•	•	•	•

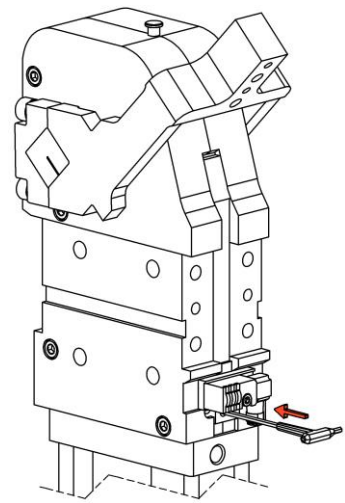

Tipo Type	Angoli d'apertura / Opening angles																												
	3	5	7	10	13	16	20	24	29	33	38	43	48	53	58	63	68	72	77	81	86	90	95	99	103	107	112	117	122
CPLM...V1 CPLM...V3	•	•	•	•	•	•	•	•	•	•	•	•	•	•	•	•	•	•	•	•	•	•	•	•	•	•	•	•	•
CPLM...H1	•	•	•	•	•	•	•	•	•	•	•	•	•	•	•	•	•	•	•	•	•	•	•	•	•	•	•	•	•
CPLM...H3	•	•	•	•	•	•	•	•	•	•	•	•	•	•	•	•	•	•	•	•	•	•	•	•	•	•	•	•	•
CPLM...V1...S	•	•	•	•	•	•	•	•	•	•	•	•	•	•	•	•	•	•	•	•	•	•	•	•	•	•	•	•	•
CPLM...V3...S	•	•	•	•	•	•	•	•	•	•	•	•	•	•	•	•	•	•	•	•	•	•	•	•	•	•	•	•	•
CPLM...H1...S	•	•	•	•	•	•	•	•	•	•	•	•	•	•	•	•	•	•	•	•	•	•	•	•	•	•	•	•	•
CPLM...H3...S	•	•	•	•	•	•	•	•	•	•	•	•	•	•	•	•	•	•	•	•	•	•	•	•	•	•	•	•	•

Ricambi.

Spare parts.

# Kit	Immagine Picture	Descrizione Description	Articolo Article
Gruppo leva Arm assembly		Leva V1C / H1C / V1CS / H1CS Arm V1C / H1C / V1CS / H1CS	06635/C
		Leva V1D / H1S / V1SS / H1DS Arm V1D / H1S / V1SS / H1DS	06656/DX/C
		Leva V1S / H1D / V1DS / H1SS Arm V1S / H1D / V1DS / H1SS	06656/SX/C
		Leva tipo V1CDS e O1CDS Arm type V1CDS and O1CDS	06656/CDS/C
		Leva V3C / H3C / V3CS / H3CS Arm V3C / H3C / V3CS / H3CS	10029/C
		Leva V3D / H3S / V3SS / H3DS Arm V3D / H3S / V3SS / H3DS	10029/DX/C
		Leva V3S / H3D / V3DS / H3SS Arm V3S / H3D / V3DS / H3SS	10029/SX/C
Finecorsa Proximity switch		Finecorsa induttivo VEP completo (0°-90°) Inductive proximity switch VEP (0°-90°)	09960/L/C
Kit guarnizioni Seals kit		Guarnizioni cilindro pneumatico Seal components for pneumatic cylinder	SCR-CPL80

